

* The KOBUS variant is still integrated in the system, but is currently no longer updated and has been discontinued.

Operating Manual Multichannel data acquisition for KOBUS and KOBOLD handheld devices

as of version V1.5

BUS-S20M

The screenshot displays the BUS-S20M software interface. At the top, a status bar shows a warning: "2009-09-29 14:49:16 HND... 80, ID: 023 00473 (4)The desired cyclotime of 500 ms was exceeded by 234 ms." The main interface is divided into several panels:

- Module synoptical table:** A table listing device identification, serial numbers, display values, units, query terms, and system states.

Identification	Serial number	Display Value	Unit	Query term	System state
023 00470	43.5	% r.F.	2009-09-29 14:54:37	Min Alarm	
023 00471	24.1	°C	2009-09-29 14:54:36	Min Alarm	
023 00472	978.2	hPascal	2009-09-29 14:54:36	Max Alarm	
023 00473	10.9	°C	2009-09-29 14:54:36		
- Temperature (24.1 °C):** Shows a large digital readout with min/max values (23.3 / 27.8) and alarm limits (25.0 / 60.0).
- Pressure (978.3 hPascal):** Shows a large digital readout with min/max values (978.2 / 978.4) and alarm limits (300.0 / 970.0).
- Humidity (10.9 °C):** Shows a large digital readout with min/max values (10.8 / 26.2) and alarm limits (-40.0 / 60.0).
- Graphs:** Two time-series plots are shown. The top graph displays pressure in hPascal over time, with a peak around 14:53. The bottom graph displays relative humidity (% r.F.) over time, showing a sharp increase during a "Fenster offen" (window open) event on 2009-09-29 at 14:52:29.0, reaching 88.8% r.F.

- Please carefully read these instructions before use!
- Please consider the safety instructions!
- Please keep for future reference!



KOBOLD Messring GmbH
 Nordring 22-24 • D-65719 Hofheim am Taunus
 ☎ +49 (0) 6192 299 0 📠 +49 (0) 6192 233 98 🌐 info.de@kobold.com

Index

1	GENERAL NOTE	3
2	SAFETY	3
2.1	INTENDED USE	3
2.2	SAFETY SIGNS AND SYMBOLS	3
2.3	SAFETY GUIDELINES	3
3	PRODUCT SPECIFICATION	4
3.1	SCOPE OF SUPPLY	4
3.2	SYSTEM REQUIREMENTS	4
3.3	TECHNICAL DETAILS	4
4	HANDLING	4
4.1	INSTALLATION AND COMMISSIONING	4
4.2	LAYOUT OF USER INTERFACE	5
4.3	MENU AND STATUS PANEL	5
4.3.1	<i>Menu bar</i>	5
4.3.2	<i>Status bar</i>	5
4.3.3	<i>Tool bar</i>	5
4.3.4	<i>Error list</i>	5
4.4	NAVIGATION PANEL	6
4.4.1	<i>Symbol group</i>	6
4.4.2	<i>Bus system</i>	6
4.4.3	<i>Context menu</i>	7
4.5	SCANNING CYCLE	7
4.6	PROGRAM SETTINGS	8
4.6.1	<i>Tab 'Security'</i>	8
4.6.2	<i>Tab 'File export'</i>	8
4.7	MODULE DISPLAY	8
4.7.1	<i>Large digit display</i>	9
4.7.2	<i>Chart display</i>	9
4.7.3	<i>Table display</i>	10
4.7.4	<i>Module synoptical table</i>	11
4.8	TOOLS	12
4.8.1	<i>Databaseviewer</i>	12
4.9	START AND STOP RECORDINGS	14
4.10	QUICK START GUIDE	15
4.11	FAQ	16

1 General Note

Read this document carefully and get used to the operation of the device before you use it. Keep this document within easy reach near the device for consulting in case of doubt.

Mounting, start-up, operating, maintenance and removing from operation must be done by qualified, specially trained staff that have carefully read and understood this manual before starting any work.

The manufacturer will assume no liability or warranty in case of usage for other purpose than the intended one, ignoring this manual, operating by unqualified staff as well as unauthorized modifications to the device. The manufacturer is not liable for any costs or damages incurred at the user or third parties because of the usage or application of this device, in particular in case of improper use of the device, misuse or malfunction of the connection or of the device.

The manufacturer is not liable for misprints.

2 Safety

2.1 Intended Use

The 'BUS-S20M' software can be used for easy data logging of KOBOLD handheld instruments. With KOBOLD handheld devices you have to set them to serial communication and in case of more devices on one converter no addresses must be used twice.

2.2 Safety signs and symbols

Warnings are labeled in this document with the followings signs:



Caution! This symbol warns of imminent danger, death, serious injuries and significant damage to property at non-observance.



Attention! This symbol warns of possible dangers or dangerous situations which can provoke damage to the device or environment at non-observance.



Note! This symbol point out processes which can indirectly influence operation or provoke unforeseen reactions at non-observance.

2.3 Safety guidelines

Please do always use current operating systems with latest hot-fixes and service packs and always use the latest Software version. Depending on the bought software version an update to the latest version is for free.



Attention! Support is only possible when using a current operating system with the latest service pack, the latest software version. There will be no support from KOBOLD Messring GmbH or from their subsidiaries when using an operating system that is no longer supported by Microsoft.

3 Product Specification

3.1 Scope of supply

The scope of supply includes:

- Manual

3.2 System requirements

- Mouse, keyboard
- 1.0 GHz processor (suggested 1.6 GHz dual core processor)
- 1 GB RAM, 150 MB hard disc (your databases need additional disc space)
- Resolution: at least 1024x764

KOBOLD interface converter

- free serial interface (COM1...255) for HND-Z031
- or free USB-interface for HND-Z032
- Vista, Windows 7 or Windows 8 (or corresponding server operating system) with latest Service Pack. (Software will run from Windows XP)
- Microsoft .net Framework Version 4.0 with latest Service- and Language Pack

3.3 Technical details

The program uses a SQLite database. Its installation and administration is completely done by the 'BUS-S20M' software. You need no knowledge in databases or SQL to use the program.

4 Handling

The handling of the software is based on standard Windows programs. Some basic Windows knowledge is required to run this software successfully

4.1 Installation and commissioning

- Download the BUS-S20M software from the product page of the corresponding HND device: HND-F, HND-P or HND-T on our homepage www.kobold.com.
Unzip the file into a desired directory on your computer.
- Install [Microsoft .NET Framework 4.0](#)
- Follow instructions of the installation program.
- Now the software can be started by clicking the 'BUS-S20M' symbol. You can find it at Start/Programs/BUS-S20M or (optionally) on your desktop and Quick Launch bar.

4.2 Layout of user interface

The user interface is divided in eight elements and areas:

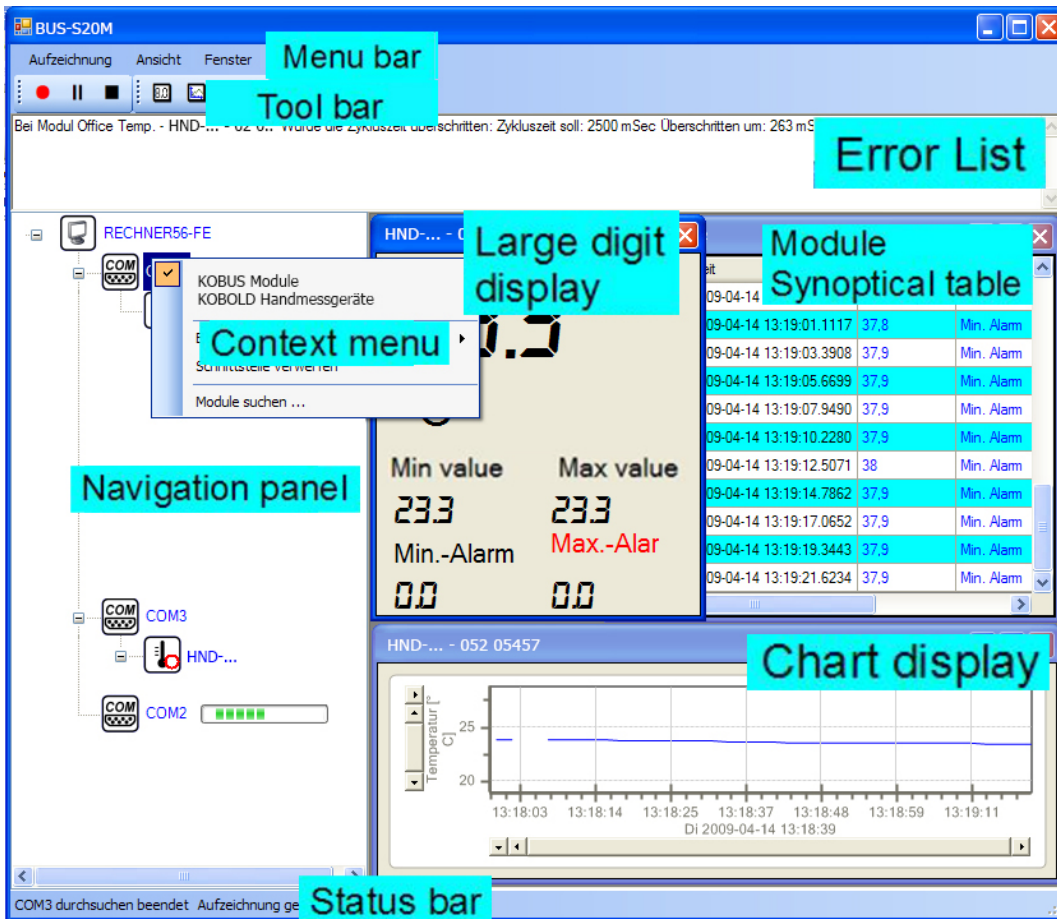

- Menu bar
- Tool bar
- Error list
- Navigation panel
- Status bar
- Chart display
- Large digit
- Table display

4.3 Menu and status panel

4.3.1 Menu bar

All program function can be reached via the menu bar.

The menu is arranged due to its intuitive structure.

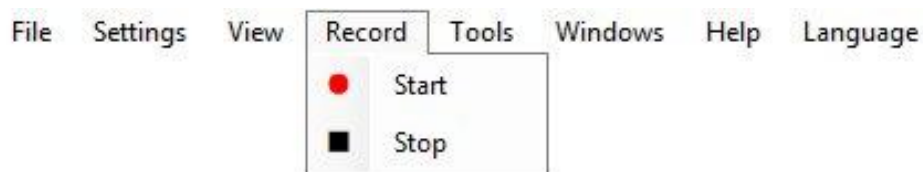

4.3.2 Status bar

The status bar lists the latest system information, i.e. if logging is currently activated or the task the program runs currently.

4.3.3 Tool bar

Frequently used functions can be started via the buttons at the tool bar. This saves you long navigation through the menu.



4.3.4 Error list

The error list specifies database and communication errors. The latest error is at the list's beginning.

4.4 Navigation panel

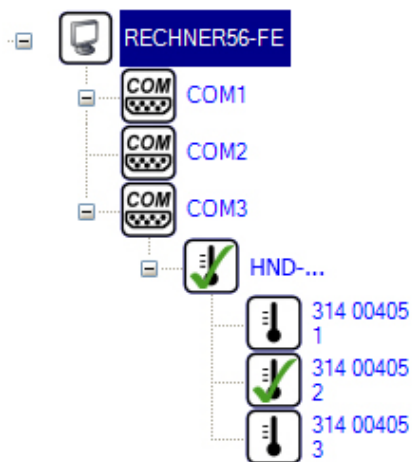

The main settings and adjustments of the program can be done at the Navigation panel. Here the bus system is selected, connected modules are searched for and the device or recording settings are adjusted.

The operations are done via the context menu that can be reached by a right click on the desired symbol.

The items of the Context Menu differ corresponding to the Symbol group.

4.4.1 Symbol group

4.4.1.1 Computer

The symbol for your computer:
Here you can select the COM interfaces that are used.



4.4.1.2 COM interface

The symbol for a COM-interface of the computer: Here you can select the used system and search for connected modules.



4.4.1.3 Modules

Each icon stands for a measuring channel connected to the COM-interface. At the context menu you can adjust the scanning cycle of the module and whether it should be added to recording.



The labels next to the symbols differ from used Bus system and module type. The displayed symbols correspond to display unit, measuring type and module type; they cannot be changed.

4.4.2 Bus system

4.4.2.1 KOBOLD handheld instruments

Here exists no unique serial number. Thus serial number and address are displayed.

For multi-channel devices an additional higher grouped symbol with device type and number of channels is displayed.

Then the single channels follow with their channel name, measuring type and ID number.

For having a 'valid' KOBOLD-System you have to set the instruments addresses manually on each instrument.

4.4.3 Context menu

4.4.3.1 Context menu computer



All available interfaces are listed here. Click on an interface to checkmark and add it under the computer symbol. Clicking an already marked interface will

remove the checkmark and delete the corresponding interface symbol. This will also remove all detected modules. After an interface is added you have to seek for connected modules again.



4.4.3.2 Context menu COM-interface



Settings concerning the connected bus system can be adjusted here. You can select either 'KOBUS modules' or 'KOBOLD handheld instruments' for your bus system. If 'KOBUS modules' is used, the connected interface converter has to be selected at 'Bus and interface settings'.

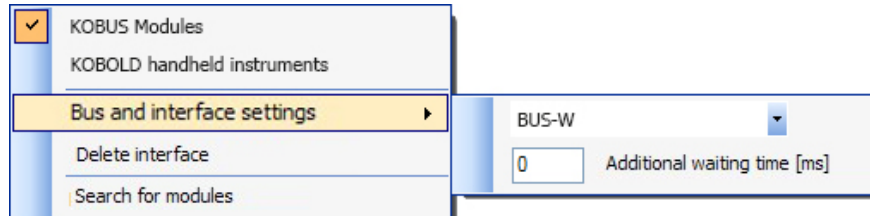

Normally 'BUS-W' is the correct selection.

If virtual COM ports are used, it may be necessary to set 'Additional waiting time' (in milliseconds). This is needed i.e. for LAN 3000, because it needs some time to prepare data. If the interface converter is connected directly, 'Additional waiting time' should be set to 0ms.

Finally the connected system can be analysed by clicking 'Search for modules'. Detected modules are allocated to the corresponding COM interface. You may also poll more than one interface at the same time. 'Delete interface' will remove the interface and all detected modules from the Navigation panel. After re-adding a removed interface you have to adjust all settings again (including the search for connected modules!).

4.4.3.3 Context menu module



Here you can select the measuring channels being added to recording and choose their scanning cycle. The scanning cycle can be set by input of value and unit of time, i.e. '60 s' or '1 min' if you want a scanning cycle of one minute. Valid unites are milliseconds (ms), seconds (s), minutes (min), hours (h) and days (d).

The value is rounded to 0.5 s. The minimal value of the scanning cycle is 0.5 s.

If a module is added to the recording process a green checkmark is displayed in the module icon at the Navigation panel as long as logging has not been started.

If the recording process is active a red dot is display instead of the checkmark.



4.5 Scanning cycle

The scanning cycle is the time period with which a module is read-out. The scanning cycle can be set for each module at the navigation context menu. Therefore enter the desired value plus unit. Both '120 s' and '2 min' are valid inputs for a scanning cycle of two minutes.

It is recommendable to set the scanning cycle not smaller than 2.5 seconds. If the scanning cycle cannot be kept, an error message is displayed in the error list. You should increase the scanning cycle if this error occurs repeatedly. This can be done even while the recording process is active.

The entered value is rounded to 0.5 s.

4.6 Program settings

The 'program settings' window is called via 'Settings' in the menu bar.

4.6.1 Tab 'Security'

4.6.1.1 Use authentication

If this function is activated security-relevant actions need authentication. The Windows account of the currently logged in user is used for this. If authentication fails the corresponding action is not carried out.

If that function is activated, for example a running recording process is only stopped if authentication has been successful.

4.6.1.2 Acoustic alarm signal

If this function is activated there is a beep when an error occurs. (functional soundsystem or PC-speaker assumed)

4.6.2 Tab 'File export'

The file export settings can be adjusted here.

4.6.2.1 Column separator

Specifies the separator between two columns.

4.6.2.2 String separator

Specifies the separator the string is written between. For example: Let the string be ABC and the string separator ' then 'ABC' is exported.

4.6.2.3 Data compression

Here you can compress recorded data. If the same value is measured for a longer period only the first and last measuring point will be saved.

4.6.2.4 Windows time format

Here you can switch between 'Windows time format' (i.e. '40016.4689467014' floating point number) and clear text time format (i.e. '2009-09-21 13:44:12.7421' string).

4.7 Module display

You can open the module display window by a double-click on the corresponding module in the navigation window while the recording process is running. Several appearances can be chosen via the symbols in the tool bar appearing after a module display window has been opened. Clicking such a symbol will only change the appearance of the active module display, but let the others unaffected.

You can choose between 'large digit display', 'table display' and 'chart display'. It is possible to have all of these appearances for one module at the same time. Therefore open the module display three times and change their appearances to the three possibilities.

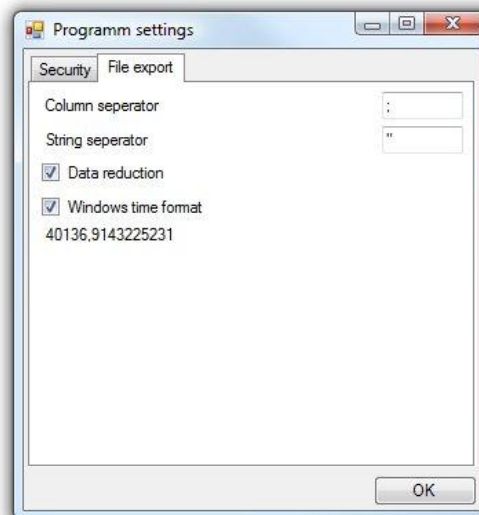

4.7.1 Large digit display



Click this icon in the tool bar to activate the large digit display for the active module window.

In this mode the current measuring value with the corresponding unit is displayed. Additionally the lowest and highest value measured during the recording is shown as well as the min and max alarm boundaries of the module.

If the measuring value falls below or exceeds the alarm boundaries the corresponding alarm gets red and the measuring value blinks red

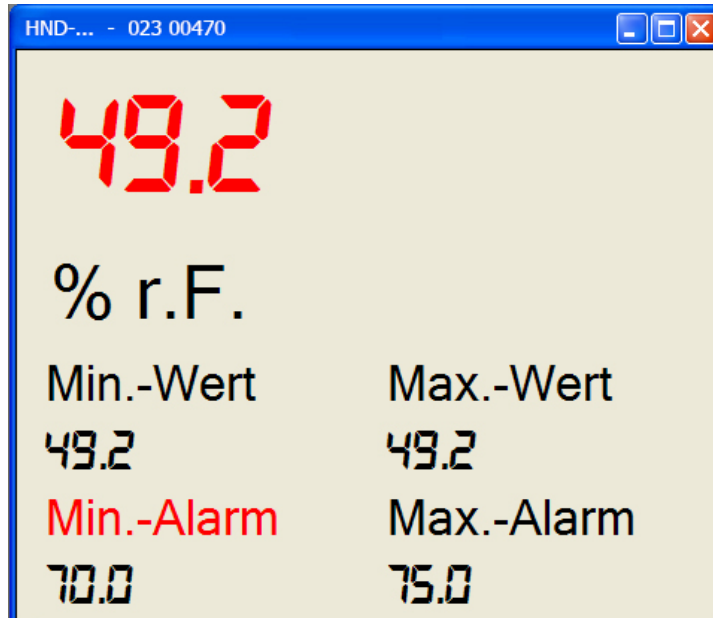

4.7.2 Chart display



Click this icon in the tool bar to display the recorded data as chart.

The chart may be actualised with little delay (depending on system load and number of connected modules).

If you have activated the chart display mode for the selected module display window there are some new icons in the tool bar. These allow you for example to display a symbol for each measuring point, insert a cursor or to export the chart.

The min and max alarm boundaries are displayed by areas in a blue- or red-toned color. The curve hitting for example the blue area indicates that the measuring value has fallen below the min alarm for some time.

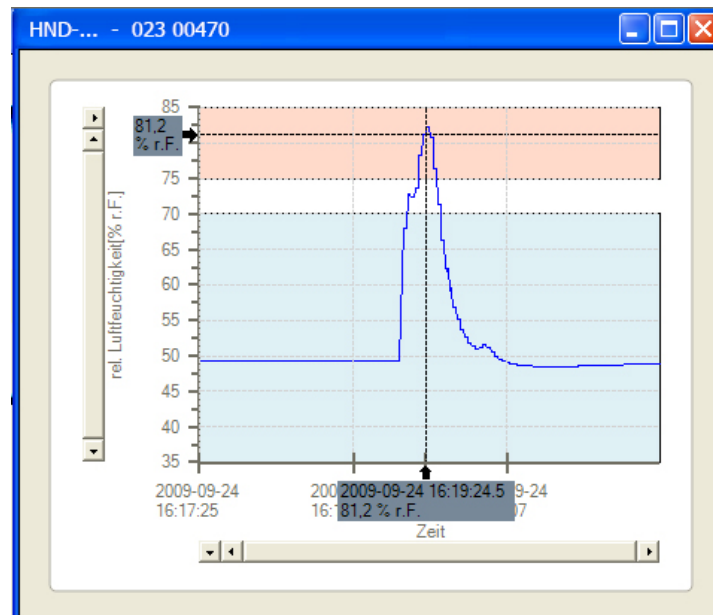

4.7.2.1 Change line and symbol color

Both curve and symbols can be displayed in other colors than the default ones. Double-click the curve in the chart display to open the dialog window. There you can set the desired color for line and measuring points and the line width.

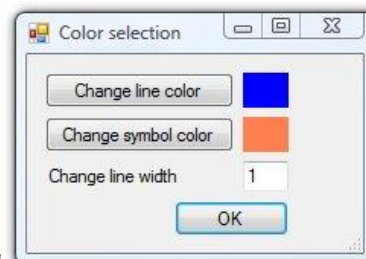

4.7.2.2 Zoom area

To zoom in the chart you have to activate the 'zoom mode' first. Therefore right-click on the chart and a context menu appears. There open the point 'zoom' and then left-click on 'zoom mode'. Your mouse pointer changes to a cross. Now you can draw a frame round the area you want do enlarge.

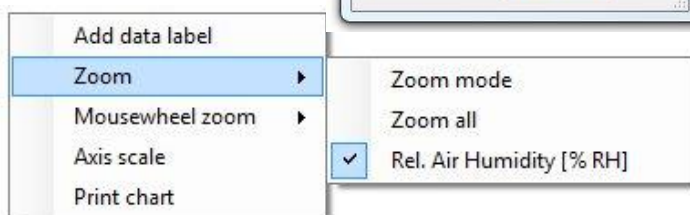

4.7.2.3 Scaling up / down

All axis, selected at the point 'mousewheel zoom', can be scaled up or down by your mousewheel.

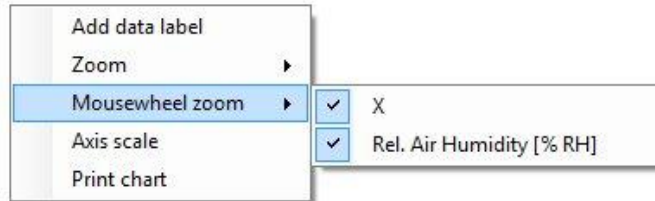

4.7.2.4 Data labels

You can add data labels to measuring points.

Right-click the desired point in the chart and click then in the opened context menu on 'data label'. The label is now displayed next to the curve. You can move it up and down by 'drag&drop'. A line will display the point the label is related to. If you want to remove or edit an existing label

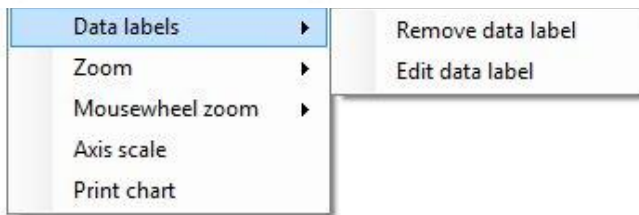

Note! To edit or delete an existing label, right-click on it to open the context menu and select 'Data labels' -> 'Edit data labels' or 'Data labels' -> 'Remove data label'.



Attention! When opening with 'Tools'->'Databaseviewer' no datalabels will be saved during a recording as you are working with a copy of the database.

4.7.2.5 Tool bar

You can select several functions for the active chart here.

4.7.2.5.1 Cursor

 Clicking this icon will add a cursor to your chart. If a cursor is already added, you will remove it. The cursor shows time and corresponding measuring value.

4.7.2.5.2 Symbols for each measuring point

 For each measuring point a symbol is displayed. This may have a negative influence on the clarity for charts with many measuring points, because the symbols may overlap.

4.7.2.5.3 Grid lines

 Grid lines are displayed for time and measuring value axis. The grid lines are set corresponding to the scale of time and measuring axis.

4.7.2.5.4 Legend

 Toggle on/off legend. The legend provides information on the measuring curve.

4.7.2.5.5 Export picture

 The chart is exported as a picture. You can choose between several popular formats.

4.7.2.5.6 Export data

 The chart is exported in a data file. You can choose between several popular formats (corresponding to program version). File-dependent settings can be adjusted at the program.

4.7.3 Table display



Click on that icon in the tool bar to display all recorded measuring values, the corresponding points in time and system status.

The system status is displayed in clear text.

If the measuring value falls below the alarm boundaries, the index, measuring value and status is blue, if it exceeds the boundaries they are displayed in red.

If an error occurs, the corresponding line is displayed in magenta. There will be no value in the measuring value column.

You can select all data and copy selected data to clipboard via the context.

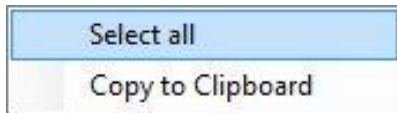

Index	Time	Value	Status
807	2009-04-14 15:12:33.4301	75,5	Max. Alarm
808	2009-04-14 15:12:33.5551	75,5	Max. Alarm
809	2009-04-14 15:12:33.8049	75,5	Max. Alarm
810	2009-04-14 15:12:33.9299	75,5	Max. Alarm
811	2009-04-14 15:12:34.1797	75,5	Max. Alarm
812	2009-04-14 15:12:34.9293		Transmission error: sensor module not responding
813	2009-04-14 15:12:35.5851		Transmission error: sensor module not responding
814	2009-04-14 15:12:36.6002	66	OK
815	2009-04-14 15:12:36.7719	66	OK
816	2009-04-14 15:12:36.8969	66	OK
817	2009-04-14 15:12:37.1467	66	OK
818	2009-04-14 15:12:37.3966	66	OK
819	2009-04-14 15:12:37.6464	66	OK
820	2009-04-14 15:12:37.9119	66	OK
821	2009-04-14 15:12:38.1461	66	OK
822	2009-04-14 15:12:38.3960	66	OK
823	2009-04-14 15:12:38.6458	66	OK
824	2009-04-14 15:12:38.8957	66	OK
825	2009-04-14 15:12:39.1455	66	OK
826	2009-04-14 15:12:39.2705	66	OK
827	2009-04-14 15:12:39.5359	53,6	Min. Alarm
828	2009-04-14 15:12:39.6609	53,6	Min. Alarm

4.7.4 Module synoptical table

Identification	Serial number	Display Value	Unit	Query term	System state
	000 01260	-23'	?	2009-05-06 07:11:08	Transmission error: sensor module not responding
	012 03871	18.0	°C	2009-05-06 07:11:08	
	020 00225	38.7	% r.F.	2009-05-06 07:11:08	
	032 00207	0.000	U/min	2009-05-06 07:11:08	
	052 05457	21.5	°C	2009-05-06 07:11:08	
	052 05458	41.3	% r.F.	2009-05-06 07:11:08	Min Alarm
	062 00964	0.05	PSI	2009-05-06 07:11:06	Min Alarm
	552 02863	21.5	°C	2009-05-06 07:11:06	
	552 02864	40.1	% r.F.	2009-05-06 07:11:06	

The synoptical table provides an overview of all currently recorded modules.

The current measuring value, the time of last measurement, system state, unit and serial number of the module is displayed.

A status icon is displayed for each module. If there is a error or a status message for at least one module, the corresponding status icon is additionally displayed in the upper left corner.

You can move an entry up or down by means of the arrows at the right.

The module synoptical table can only be opened if recording has been started. You can open it under 'View' 'Module synoptical table'.

4.8 Tools

Available tools are shown at this menu item.

4.8.1 Databaseviewer



Click 'Databaseviewer' to load and display the measuring values of an existing data base. You can display more than one curve in one chart with up to 2 Y-axis with different units.

4.8.1.1 Icons

Most of the icons and functions used in the data base viewer are just the same as that of the chart display (p.r.t. chart display on page 10)

Additionally there are the following icons:

4.8.1.2 Print

-  Print the current view.
-  Before the printing is started a dialogue box appears. There you can select the data you want to print. The printing starts after you have confirmed the print preview. Please consider that tables of measuring values without data reduction may need hundreds of sheets.

4.8.1.3 Tab 'Records'

Here you can select your database. Furthermore information about the modules and recordings are displayed.

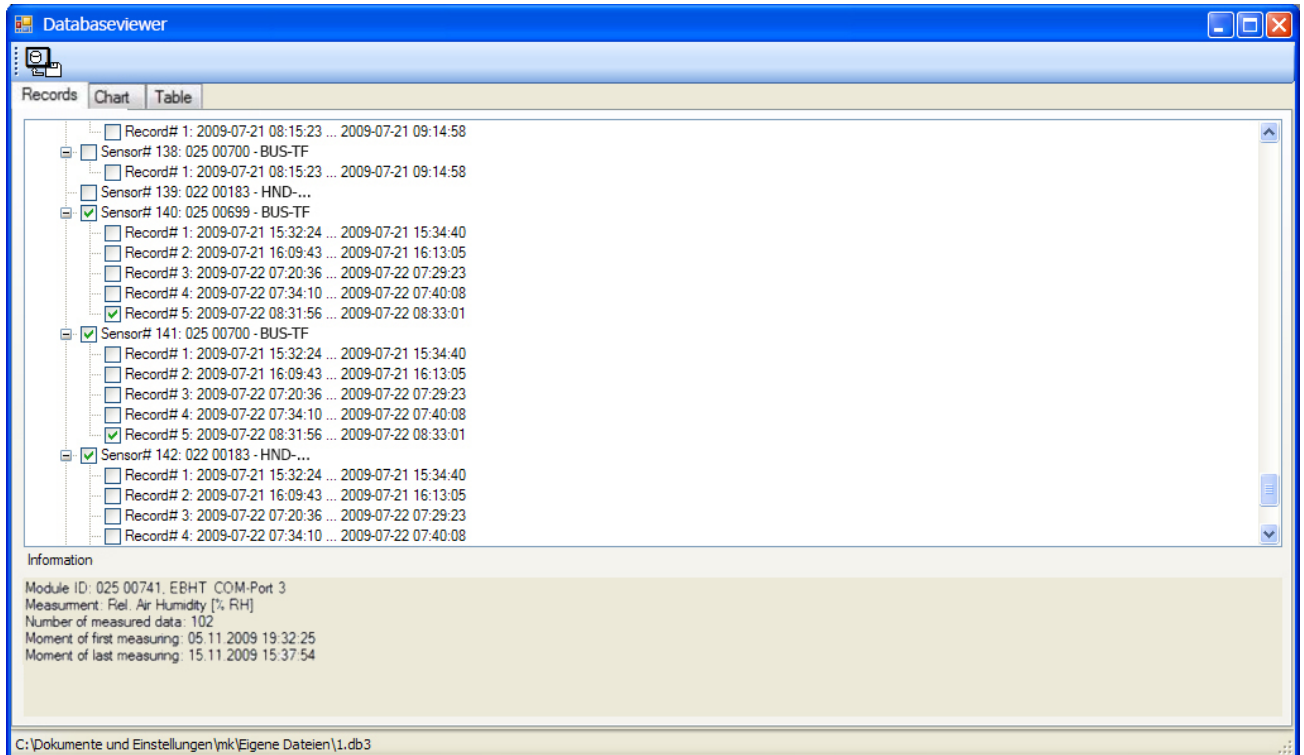

Here you can select the recordings, you want to display as chart and/or table. Just check the box before your desired recording to select it.

After you have selected all the desired recordings you can readout and display them by switching to the tabs 'Chart' or 'Table'.

4.8.1.4 Tab 'Chart'

The selected recordings are displayed as chart.

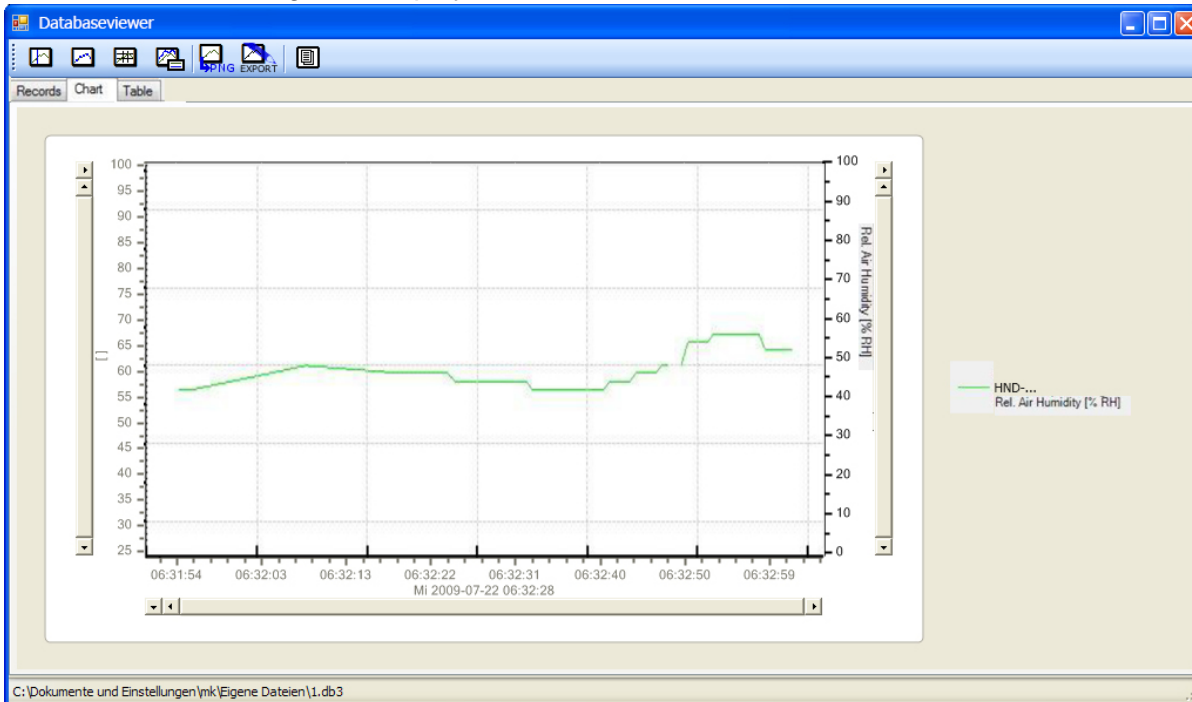

The Y-axis is labelled corresponding to type of measurement and unit. (There will be no axis label, if no valid type or unit exists.)

The tools and settings correspond to that ones of the chart display (p.r.t. chart display on page 10).



Attention! When opening with 'Tools'->'Databaseviewer' no datalabels will be saved during a recording as you are working with a copy of the database.

4.8.1.5 Tab 'Table'

A table with all the measuring values of the database is displayed. If you have activated data reduction in the program settings, the compressed data is displayed. In this case you can display all data if you deactivate the data reduction and restart the data base viewer.

Time	025 00699 Rel. Air Humidity [% RH] - 5	025 00700 Temperature [°C] - 5	022 00183 [] - 5
2009-07-22 06:32			52,7
2009-07-22 06:32		25,3	
2009-07-22 06:32			52,7
2009-07-22 06:32			52,6
2009-07-22 06:32	56,9		
2009-07-22 06:32	56,8		
2009-07-22 06:32			52,6
2009-07-22 06:32			51,6
2009-07-22 06:32			51,6
2009-07-22 06:32			89,6
2009-07-22 06:32			89,6
2009-07-22 06:32			
2009-07-22 06:32			79,7
2009-07-22 06:32			79,7
2009-07-22 06:32			57,2
2009-07-22 06:32			57,2
2009-07-22 06:32			52,3
2009-07-22 06:32			52,3

4.9 Start and stop recordings

Before you can start a recording process you have to identify the COM ports of your computer first. A right-click on the PC symbol will open the context menu.

You can find that symbol in the Navigation panel after you have started the software.

The context menu lists all available COM interfaces. Please select all COM port KOBUS modules or KOBOLD handheld instruments are connected to.

All selected COM interfaces will be displayed below the PC symbol.



Now you can select the bus system and the interface converter (where necessary) for each interface.

Afterwards you have to read in the connected system by a click on 'Seeking modules ...' in the context menu.

A progress bar next to the COM interface symbol will inform you about the status of the read-in. Detected modules are listed up immediately below the corresponding COM interface.

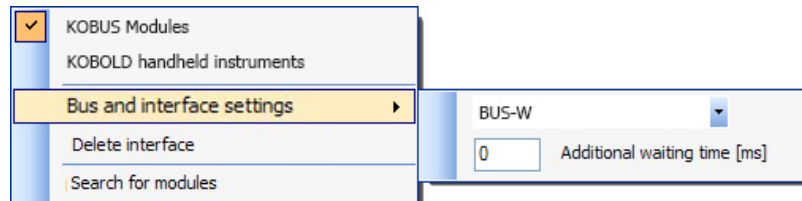

When the read-in has finished (progress bar disappears), you can select the modules that should be added to the recording process and adjust their scanning cycle.

After you have added at least one module (at least one green checkmark over a icon) you can start the recording by clicking the red button.

Alternatively you can click 'Record' → 'Start'. The green checkmark switches to a red dot if the recording progress has been started successfully.

The status bar displays a notice that a recording is running. The hibernating energy saving options like 'Suspend to RAM' (StR) or 'Standbymodus' are deactivated until the recording is stopped.



You can stop a recording process by a clicking on the 'Stop' button or click 'Record' → 'Stop'.

4.10 Quick start guide

Right-click on computer symbol and select there the desired interface.

Right-click on the interface select used interface converter and adjust its settings (if needed).

Click 'Seek modules ...'.

After the progress bar has disappeared select your desired modules and adjust the scanning cycle (right-

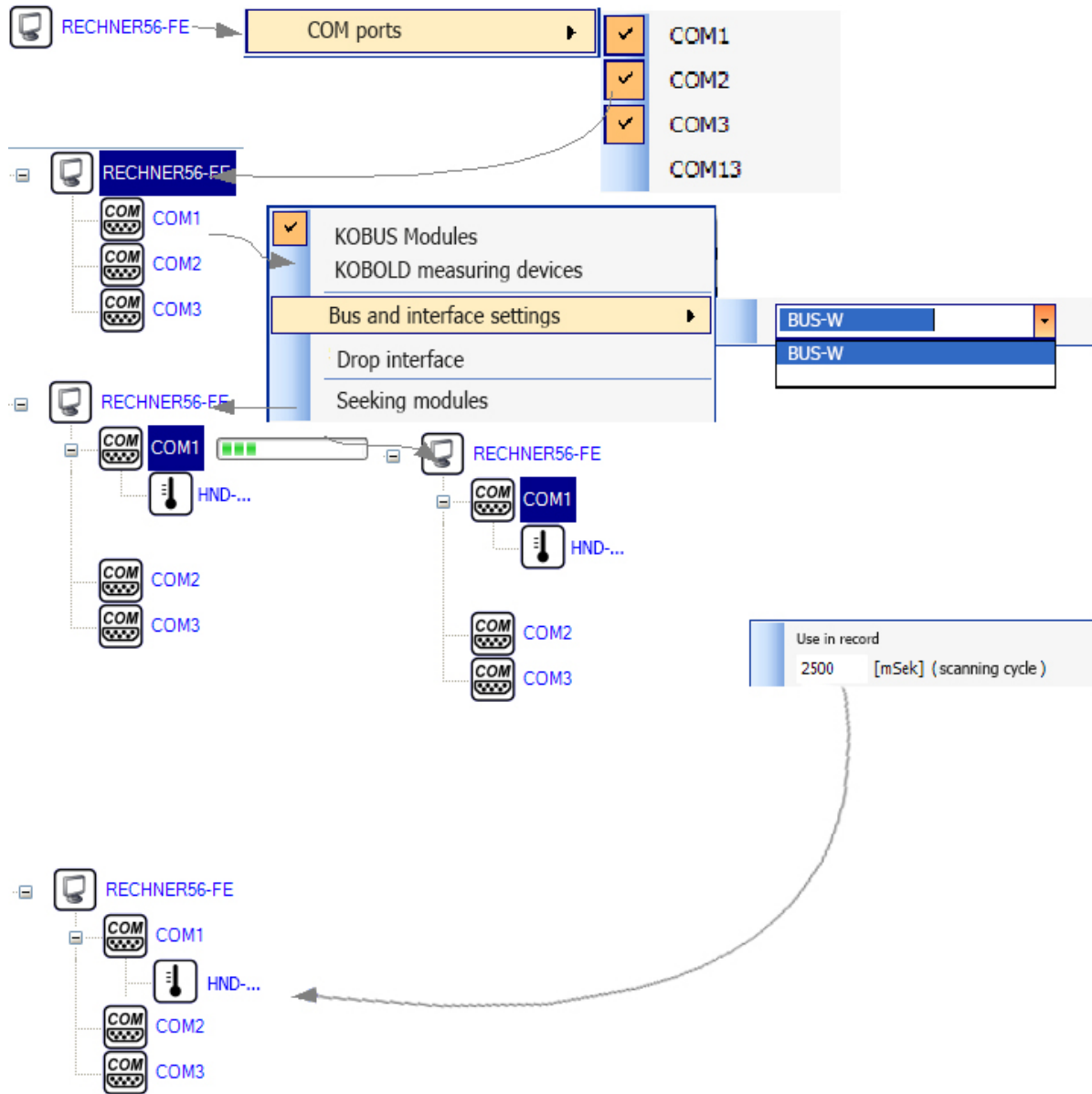

click on a module will show you its context menu)

Click on the red button in the upper left corner to start recording.

Double-click on a module will open a display frame. You can select large digit, chart, table display.

4.11 FAQ

I cannot start recording!

Is there at least one green checkmark at a module symbol in the Navigation panel?

If not, you have not selected any module to be recorded. To add a module to the recording process, you have to set the checkmark at 'Use in record' at the Navigation panel context menu.

Is there at least one red dot at a module symbol in the Navigation panel?

If so, a recording is already running.

Is there enough free hard disk space?

If not, please ensure enough disk space (at least 150 MB)

The scanning cycle equals not the period between the measured values.

The time saved in the database is exactly the time of the measurement. Therefore the chart and table display have the exact times. The actual period of time between two measured values should ideally equal the scanning cycle.

The actual period is longer than the set scanning cycle?

If so, you should increase the scanning cycle. The error list gives information about not kept scanning cycles. You can increase the scanning cycle at the Navigation panel context menu.

The actual period is shorter than the set scanning cycle?

This is just normal, because the modules are polled one after another.

There may be the case that a module does not answer. This would lead to excess of the scanning cycle for that module and therefore all following modules. In order to carry out measurement of the next modules in time, the set scanning cycle is undershot a little. This does not affect the quality of the measurement.

I cannot stop the recording process!

Is there a red dot at at least one module symbol?

If not, there is no running recording and therefore none can be stopped.

Do you have a valid Windows login?

You have to enter valid Windows login data (including user name and password) to stop the recording process. If the login fails, you have not the user authorisation to stop the recording.

You can disable this security function by unmarking the checkbox 'Authentication' at 'Security'. Then you do not have to login in order to stop a recording.

No modules are found!

Is the interface converter connected to the power supply?

Is there a bus cable connected to the interface converter and to at least one module?

Is the interface converter connected to your computer?

Is the COM-interface selected to that the interface converter is connected to?

Is the system already initialised?

If not, carry out a system initialisation via the software KOBUS-Configurator.

Has the system been changed presently?

Are all cables working?

If so, carry out a system initialisation via the software KOBUS-Configurator.

Is the right bus system selected at the Navigation panel context menu for the used COM-interface.

If not, please select the correct bus system.