



Operating Instructions
for
Relay board retrofit kit

Model: ZUB-MANS-KON1/2

ZUB-MANS-KON1/2

We don't accept warranty and liability claims neither upon this publication nor in case of improper treatment of the described products.

The document may contain technical inaccuracies and typographical errors. The content will be revised on a regular basis. These changes will be implemented in later versions. The described products can be improved and changed at any time without prior notice.

© **Copyright**

All rights reserved.

1. Contents

1. Contents	3
2. Note	4
3. Instrument Inspection.....	4
4. Regulation Use	5
5. Wiring configurations	5
5.1 Configurations for ZUB-MANS-KON1.....	6
5.2 Configurations for ZUB-MANS-KON2.....	7
6. Assembly and commissioning.....	8
7. Technical Information.....	17
8. Order Codes	17
9. Disposal	18
10. EU Declaration of Conformance	19
11. UK Declaration of Conformity.....	20

Manufactured and sold by:

Kobold Messring GmbH
Nordring 22-24
D-65719 Hofheim
Tel.: +49(0)6192-2990
Fax: +49(0)6192-23398
E-Mail: info.de@kobold.com
Internet: www.kobold.com

2. Note

Please read these operating instructions before unpacking and putting the unit into operation. Follow the instructions precisely as described herein.

The instruction manuals on our website www.kobold.com are always for currently manufactured version of our products. Due to technical changes, the instruction manuals available online may not always correspond to the product version you have purchased. If you need an instruction manual that corresponds to the purchased product version, you can request it from us free of charge by email (info.de@kobold.com) in PDF format, specifying the relevant invoice number and serial number. If you wish, the operating instructions can also be sent to you by post in paper form against an applicable postage fee.

The devices are only to be used, maintained and serviced by persons familiar with these operating instructions and in accordance with local regulations applying to Health & Safety and prevention of accidents.

When used in machines, the measuring unit should be used only when the machines fulfil the EC-machine guidelines.

3. Instrument Inspection

Instruments are inspected before shipping and sent out in perfect condition.

Should damage to a device be visible, we recommend a thorough inspection of the delivery packaging. In case of damage, please inform your parcel service / forwarding agent immediately, since they are responsible for damages during transit.

Scope of delivery:

The standard delivery includes:

- 1x relais board
- 2x fastening screws M2x16
- 1x 8-pin connector plug M12x1 (**only ZUB-MANS-KON2**)

4. Regulation Use

The accessory sets ZUB-MANS-KON1 / 2 are offered for retrofitting the digital manometer MAN-LC30. The relay board included in the delivery is mounted directly on the existing evaluation electronics and expands the device with up to 2 potential-free changeover contacts.

Any use of the device, which exceeds the manufacturer's specification, may invalidate its warranty. Therefore, any resulting damage is not the responsibility of the manufacturer. The user assumes all risk for such usage.

5. Wiring configurations

The additional relay board is a retrofittable electronic module on which two independently acting electromechanical changeover relays are integrated. Both relays are controlled by the 2 electrical outputs OUT1 and OUT2 of the MAN-LC30. The relays are only activated correctly if the corresponding output is configured as an alarm output and the associated slide switch on the board is set to ON. In the OFF position, the relay is electrically decoupled from the output and other signals such as IO-Link or a current output can then be transmitted via this output.

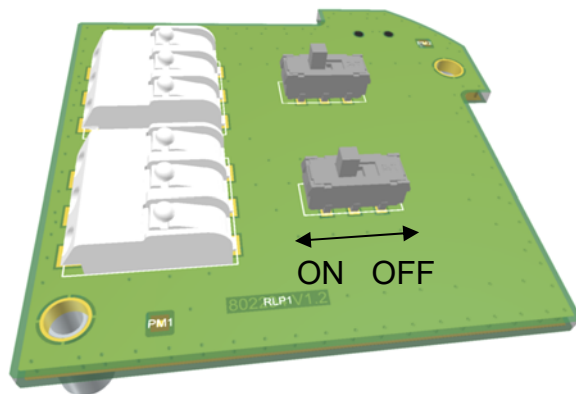

ZUB-MANS-KON1/2

5.1 Configurations for ZUB-MANS-KON1

Option	Configuration	Pin assignment M12x1 plug, 5-pin	Order code**
5.1	2x NO contact		ABG-MANLC51
5.2	2x NC contact		ABG-MANLC52
5.3	1x NO contact, 1x NC contact		ABG-MANLC53
5.4	Output 1 IO-Link, 1x NO contact		ABG-MANLC54
5.5	Output 1 IO-Link, 1x NC contact		ABG-MANLC55
5.6	Output 2 4-20 mA, 1x NO contact		ABG-MANLC56
5.7	Output 2 4-20 mA, 1x NC contact		ABG-MANLC57

** With factory configuration

5.2 Configurations for ZUB-MANS-KON2

Option	Configuration	Pin assignment M12x1 plug 8-pin	Order code**
8.1	1x NO contact / NC contact + output 2 4-20mA	<p>+Vs 1 7 4-20mA 2 8 GND 3 6 REL1 NC REL1 CO 4 5 REL1 NO</p>	ABG-MANLC81
8.2	2x NO contact / NC contact	<p>+Vs 1 7 REL2 NO REL2 CO 2 8 REL2 NC GND 3 6 REL1 NC REL1 CO 4 5 REL1 NO</p>	ABG-MANLC82
8.3	1x NO contact / NC contact + output 1 IO-Link	<p>+Vs 1 7 REL2 NO REL2 CO 2 8 REL2 NC GND 3 6 IO-Link 4 5</p>	ABG-MANLC83

** With factory configuration

6. Assembly and commissioning

The following steps must be carried out to assemble and commission the relay board:

1. Unscrew the display screw cap cover
2. Carefully remove the electronics module from the device housing (**note the limited cable length of the sensor and M12x1 connector!**)

The electronics unit must be turned so far that the rear with the connection terminals is easily accessible.

If one of the sensor connection strands slips out of the clamp connection during dismantling or assembly, it can be reconnected as shown in the picture below.

Attention: It is important to ensure that only the naked wire strand is clamped and not the wire insulation.

Rear view of electronics module unit with connected wire strands in standard design (5-pin M12x1 connector):

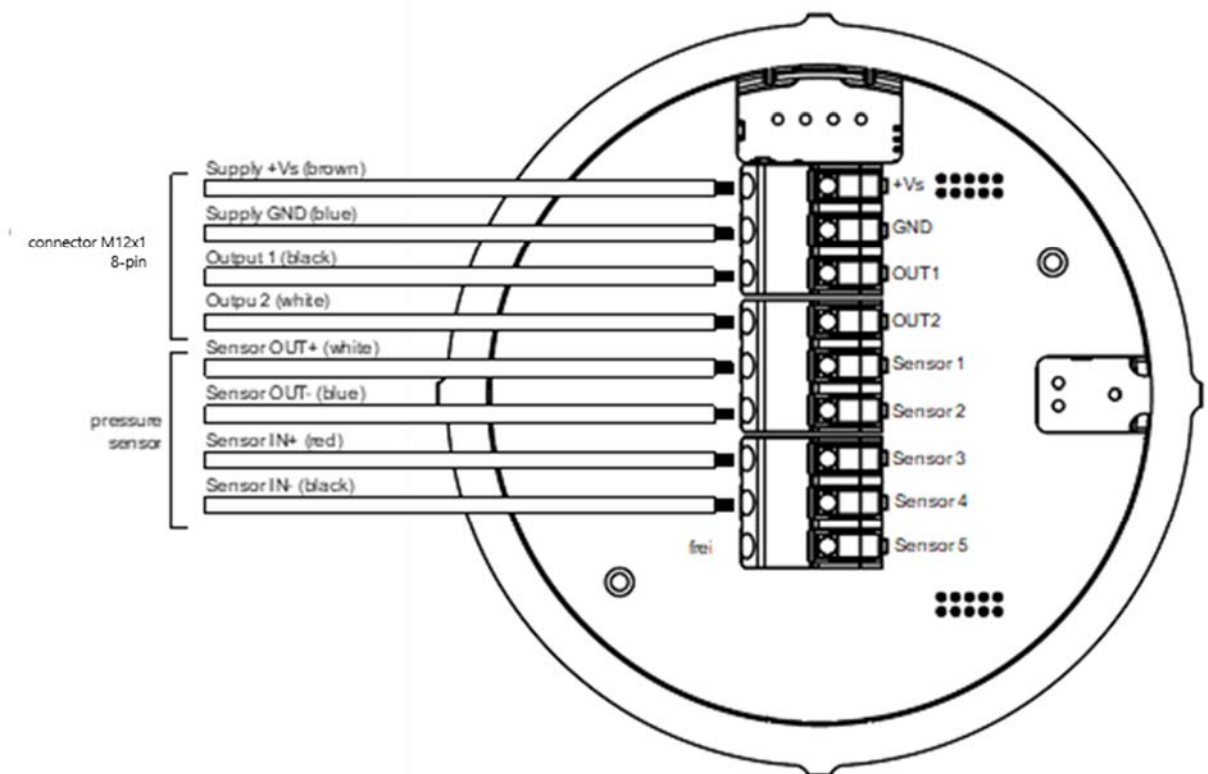

3. Depending on the desired configuration, the connection wires for output 1 (black wire) or output 2 (white wire) must now be removed from the terminals as shown in the illustration below.

With ZUB-MANS-KON1

Configurations 5.1 to 5.3:

Configurations 5.4 to 5.5:

Configurations 5.6 to 5.7:

Remove wire strands output 1 and 2

Only remove stranded wire output 2

Only remove stranded wire output 1

With ZUB-MANS-KON2

Configurations 8.1 to 8.3:

Remove wire strands output 1 and 2 + (wire strands +Vs) and GND

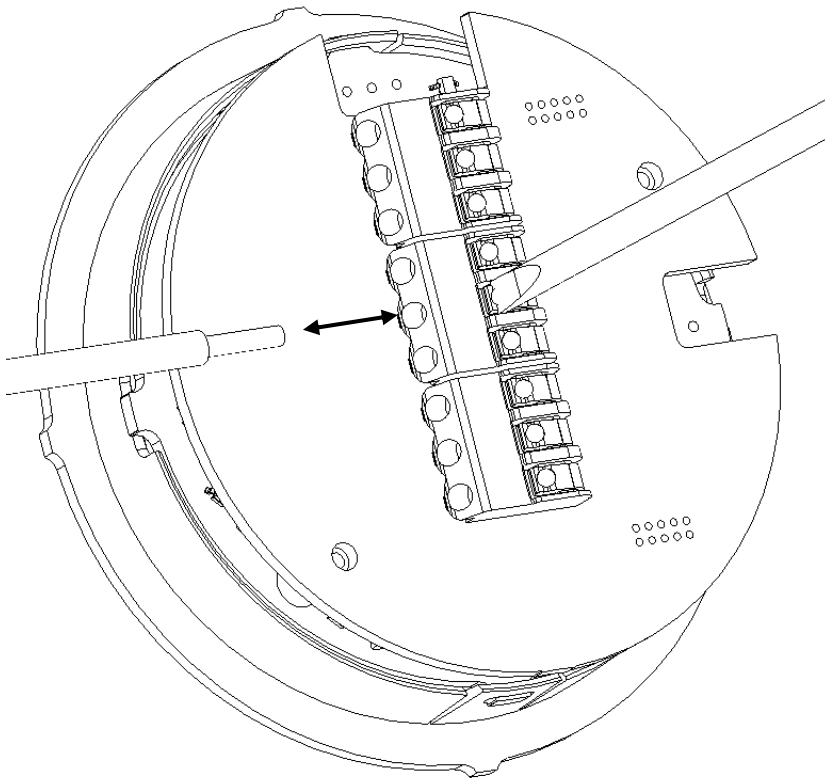

Assembly / disassembly of the connecting wires:

Press the unlocking tab (recess) down with a suitable pointed object (e.g. screwdriver) - then the connection wire can be removed or inserted. The flap must be released again to lock it in place

ZUB-MANS-KON1/2

- For **ZUB-MANS-KON2**, the complete 5-pin M12x1 built-in plug must now be removed and replaced with the 8-pin plug supplied. The dismantling / assembly is carried out from the inside with the aid of a socket or open-end wrench with wrench size SW22.

From the installed 8-pin plug, the following connection wires must be reconnected to the terminals:

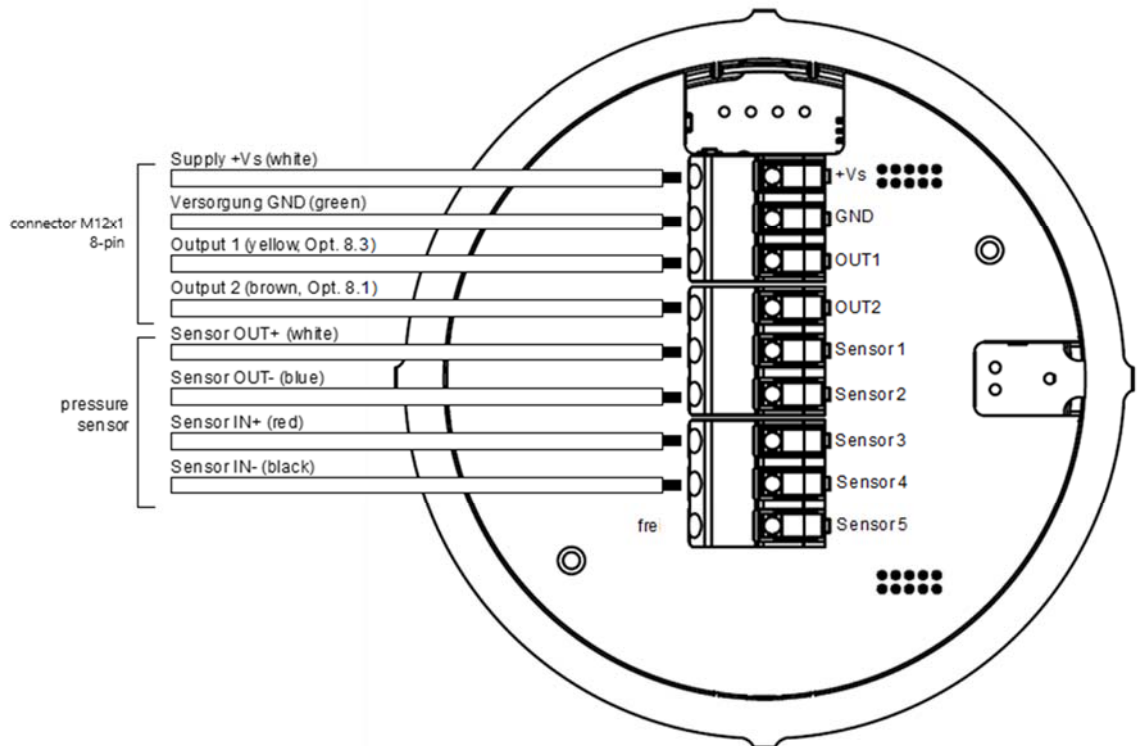

All options 8.x:	Terminal + Vs:	white wire
	Terminal GND:	green wire
Only for option 8.1:	Terminal OUT2:	brown wire
	Terminal OUT1:	open
Only for option 8.3:	Terminal OUT1:	yellow wire
	Terminal OUT2:	open

All other wire strands remain initially loose in the connection area!

5. Installation of the relay board

The relay board is to be installed as follows:

- The two M2x5 screws must be removed with a suitable screwdriver
- Align the relay board according to the picture and attach it to the electronics unit
- Connect the relay board to the electronics unit with the 2 supplied M2x16 screws (tightening torque 3 Nm)

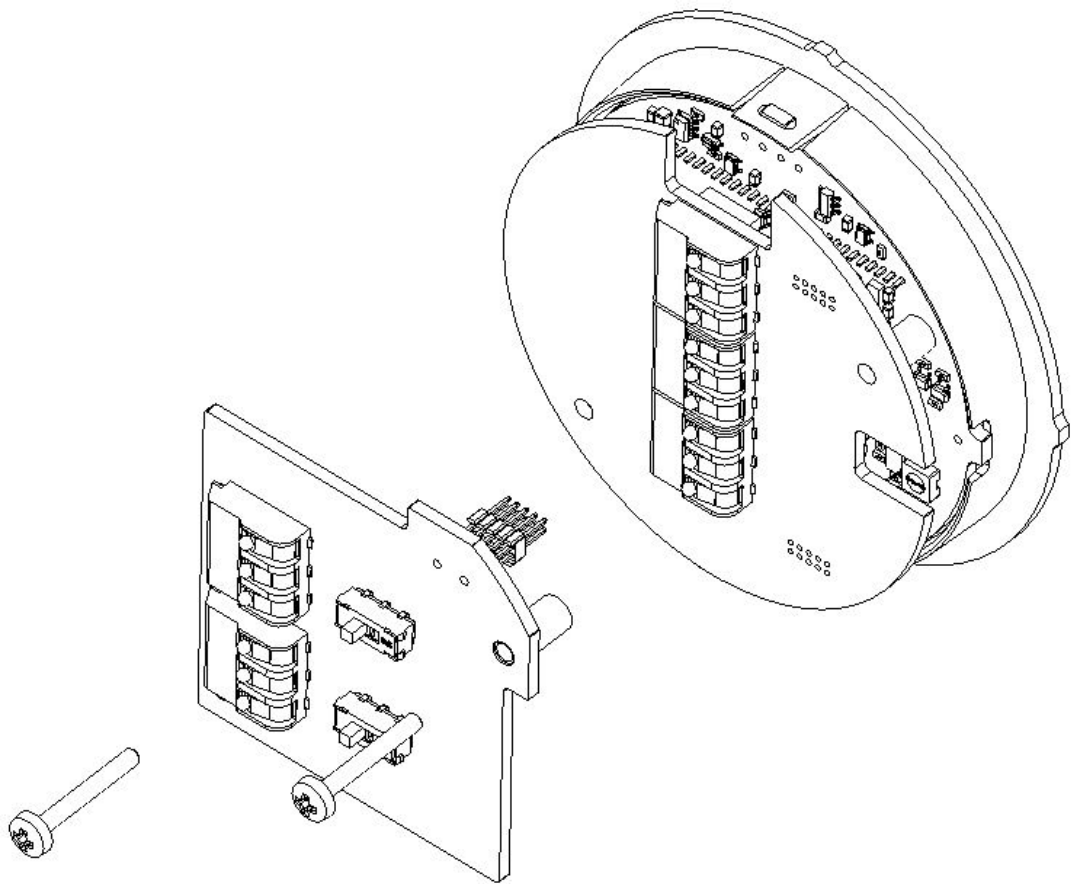

6. The free wire strands of the connector (5- or 8-pin) are now to be connected to the 2 connection terminals of the relay board as follows. In addition, the two slide switches must be brought into the correct position according to the arrows shown in the views.

ZUB-MANS-KON1/2

Option 5.1

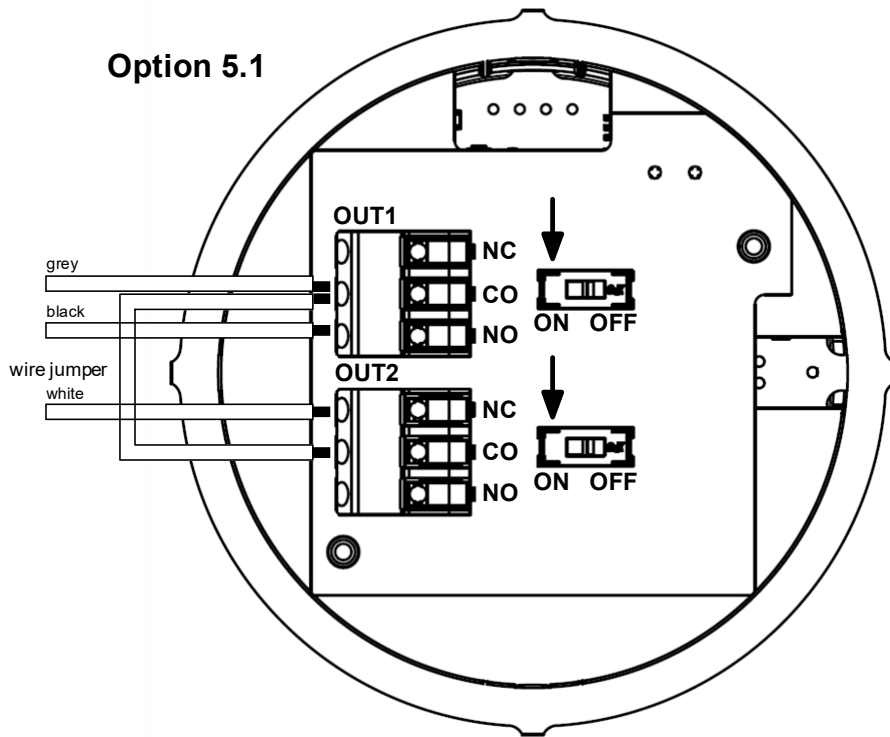

Option 5.2

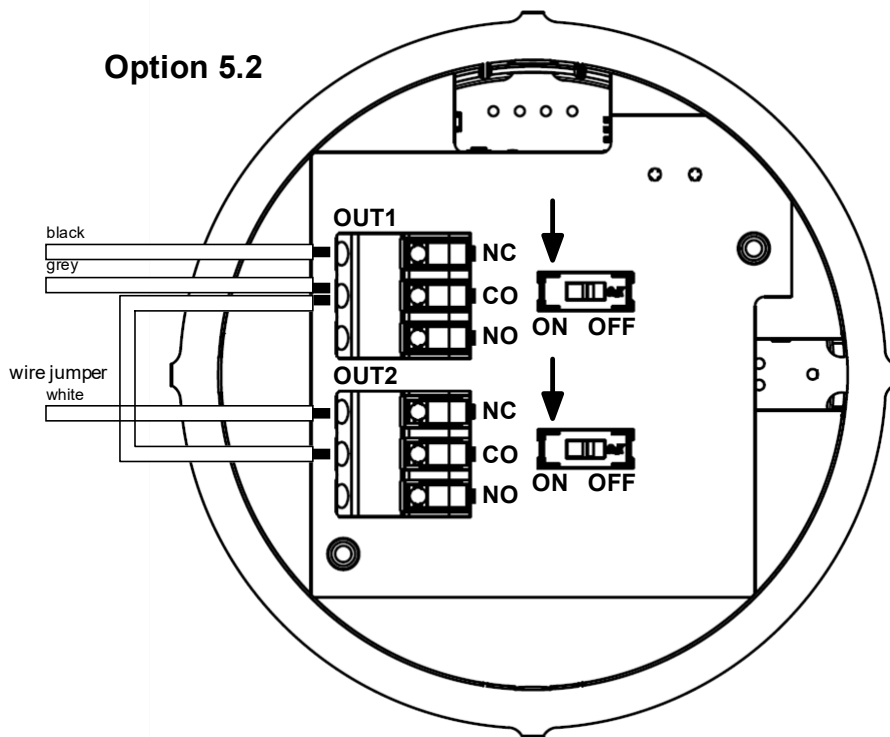

Note: To create a bridge between REL1 CO and REL2 CO, a 40 mm long piece must be cut from the gray wire, approx. 8 mm stripped on both sides and thus a bridge between the two CO terminals. For correct clamping, the individual conductors of both wire strands, which must be inserted in a terminal, must be twisted together before being inserted into the terminal.

Option 5.3

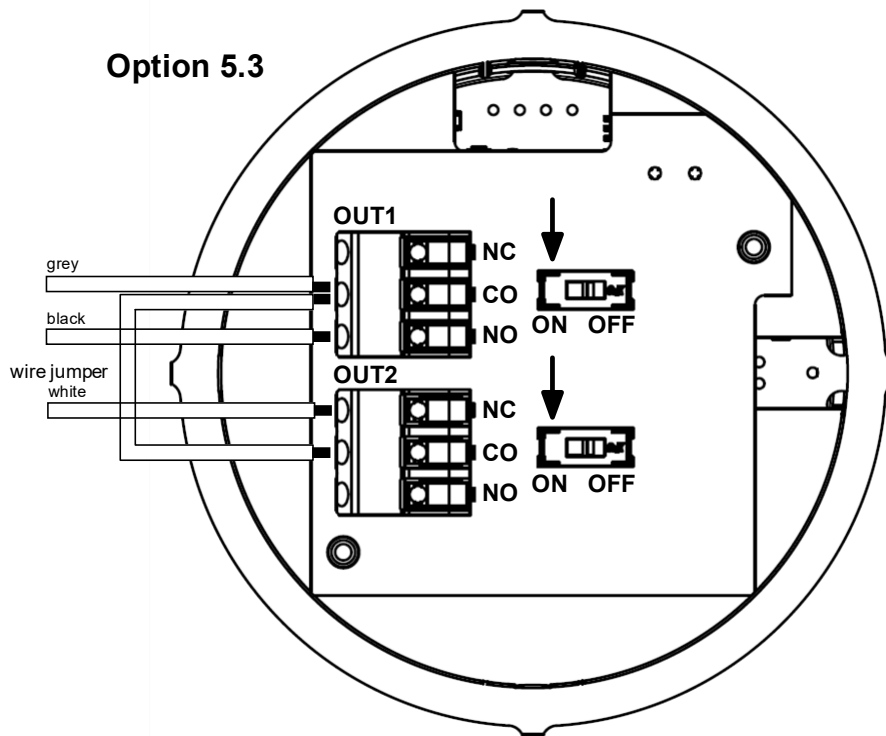

Option 5.4

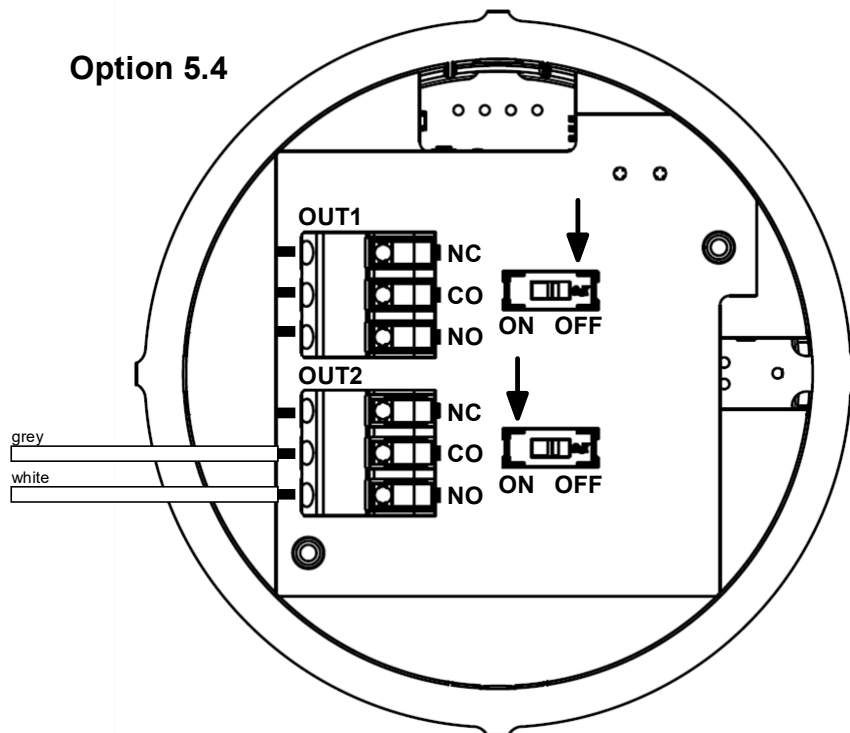

ZUB-MANS-KON1/2

Option 5.5

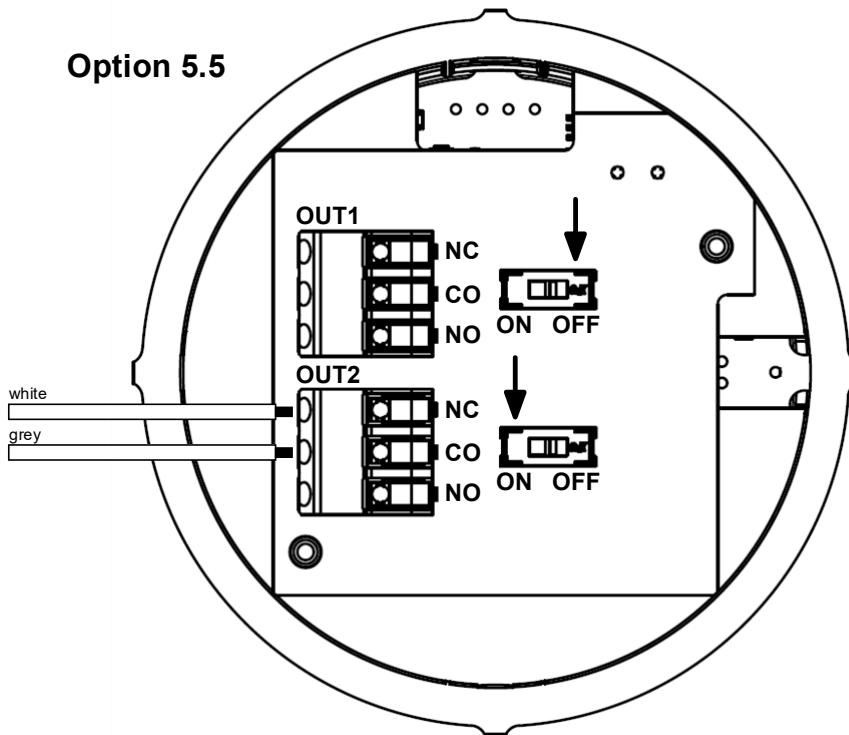

Option 5.6

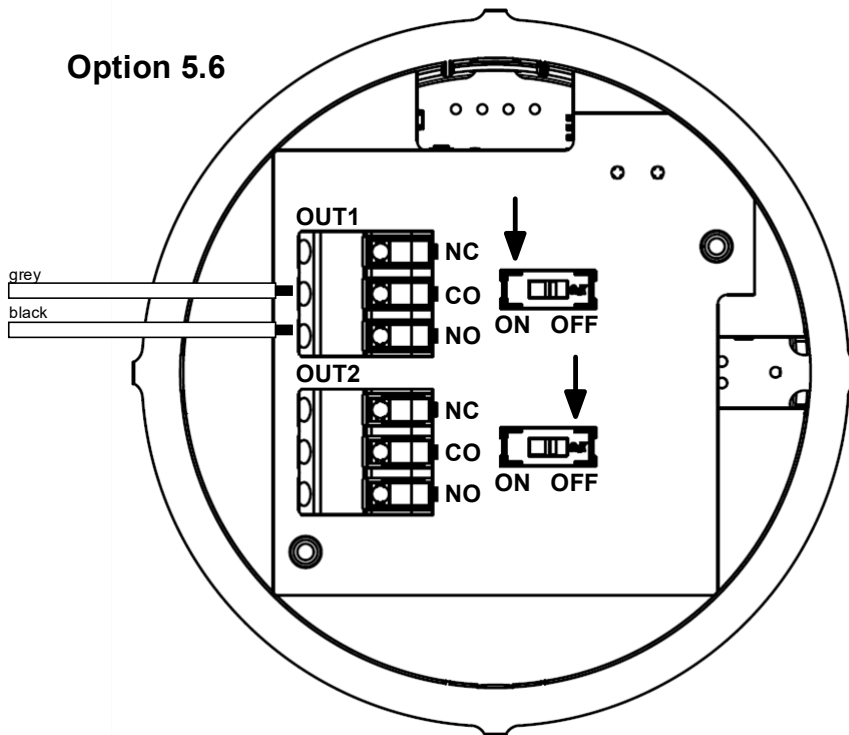

Option 5.7

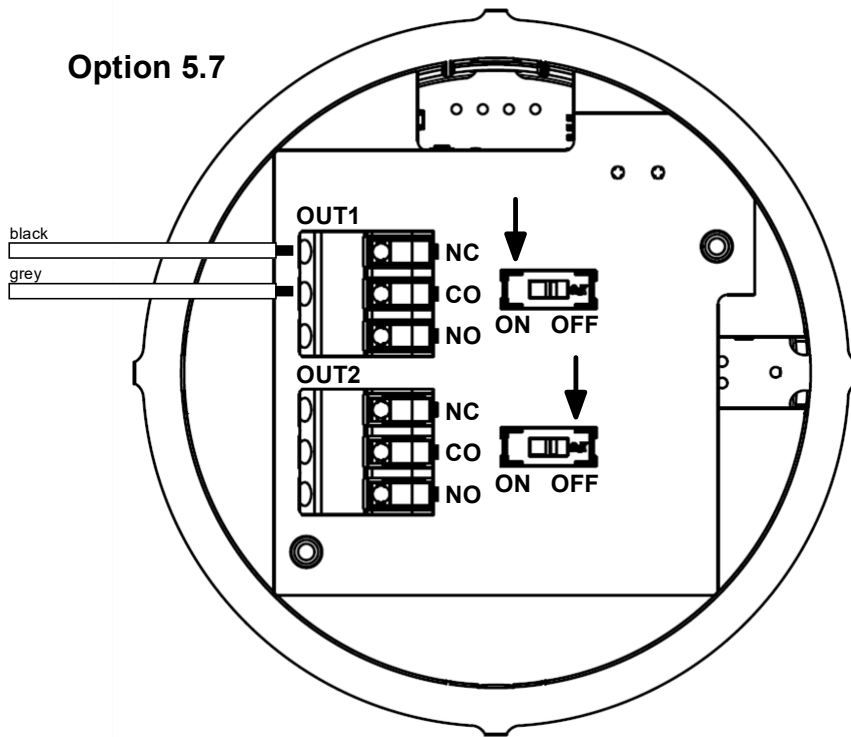

Option 8.1

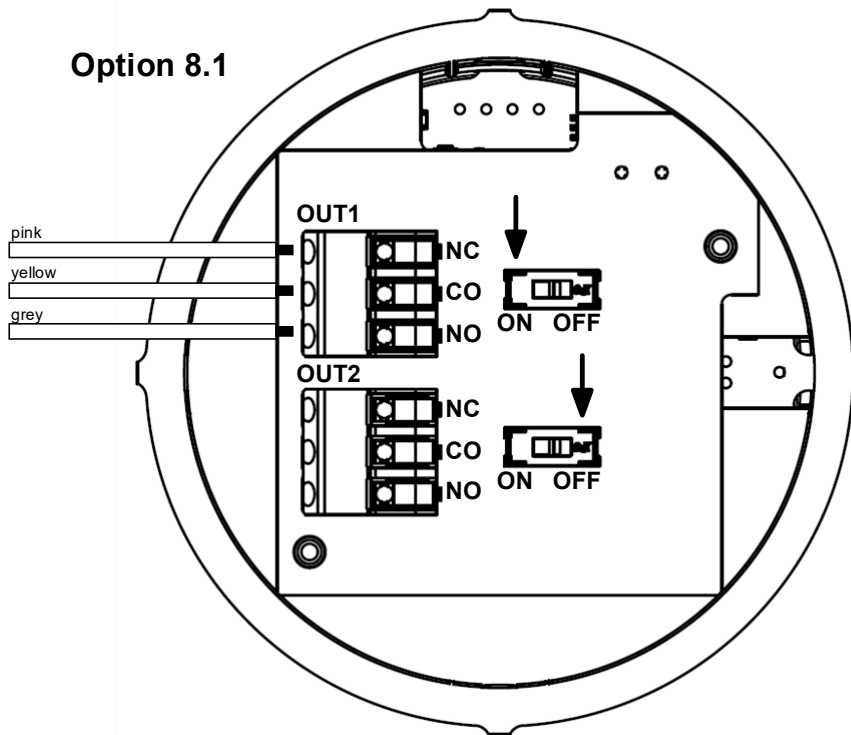

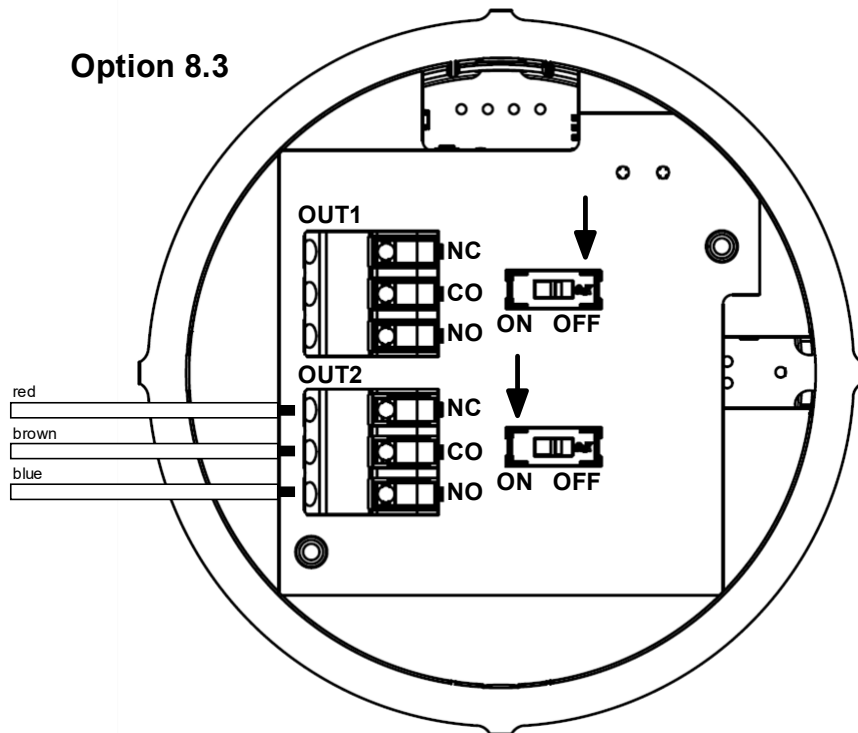
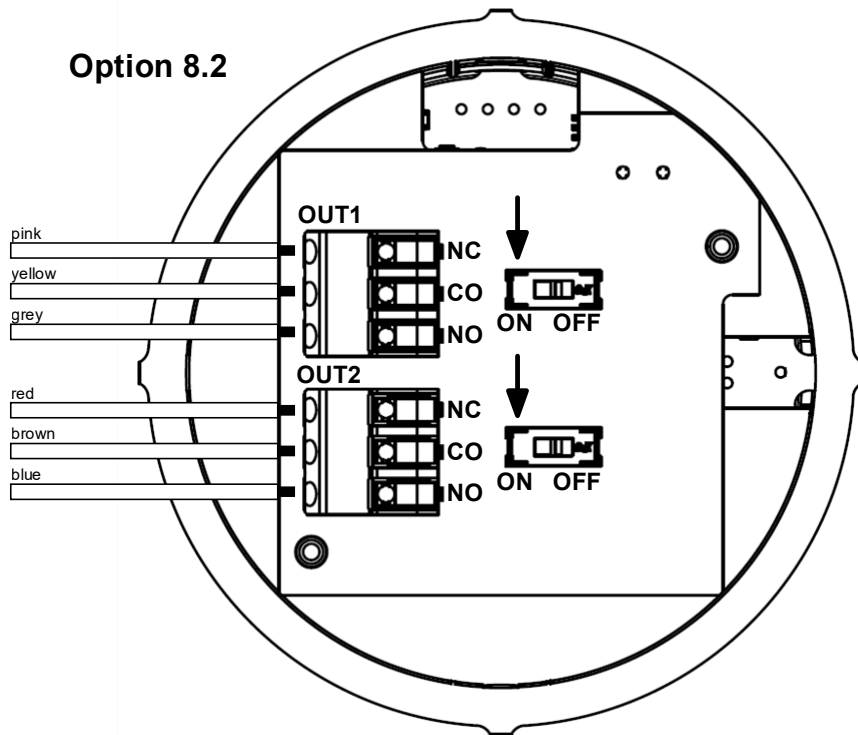

7. After clamping the connecting wire strands, stow the strands in the rear part of the electronics box and insert the electronics module back into the housing.
8. Then screw the screw cap cover back on (tightening torque max. 3 Nm)

9. Parameterization of the electrical outputs

In the device menu, the electrical outputs must now be parameterized according to the following table.

Option	OUT1		OUT2	
	Function	Parameter value	Type	Parameter value
5.1	Limit function	ALARM	Limit function	ALARM
5.2				
5.3				
5.4	IO-Link function	IOLIK		
5.5				
5.6	Limit function	ALARM	Analogue output 4-20 mA	4-20
5.7				
8.1			Limit function	ALARM
8.2				
8.3	IO-Link function	IOLIK		

Likewise, for correct control of the corresponding relay, the parameter value must be set from **TYPE** to **PNP** (positive switching) or **PP** (double-sided switching PushPull)!

7. Technical Information

Switching capacity per contact:	30 VAC / DC, max.1A
Electrical connection:	spring-loaded terminals, 0.75 mm ²
Mechanical connection:	Fixing with 2 screws M2x16 (included)
Relay activation:	1 mechanical slide switch per relay

8. Order Codes

Order codes

Model	Description
ZUB-MANS-KON1	Relay retrofit kit for MAN-LC2 potential-free changeover contacts + Mounting screws M2x16
ZUB-MANS-KON2	Relay retrofit kit for MAN-LC, 2 potential-free changeover contacts + 8-pin M12x1 flange connector + M2x16 fastening screws

9. Disposal

Note!

- Avoid environmental damage caused by media-contaminated parts
- Dispose of the device and packaging in an environmentally friendly manner
- Comply with applicable national and international disposal regulations and environmental regulations.

Batteries

Batteries containing pollutants are marked with a sign consisting of a crossed-out garbage can and the chemical symbol (Cd, Hg, Li or Pb) of the heavy metal that is decisive for the classification as containing pollutants:

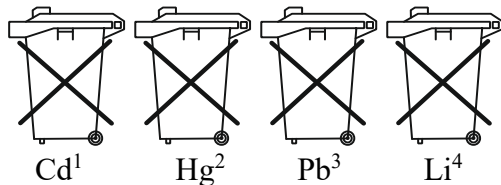

1. „Cd" stands for cadmium
2. „Hg" stands for mercury
3. „Pb" stands for lead
4. „Li" stands for lithium

Electrical and electronic equipment

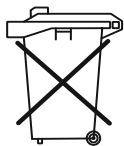

10. EU Declaration of Conformance

We, KOBOLD Messring GmbH, Nordring 22-24, 65719 Hofheim, Germany, declare under our sole responsibility that the product:

Relay extension board for MAN-LC Model: ZUB-MANS-KON1 / 2 ...

to which this declaration relates is in conformity with the following EU directives stated below:

2014/30/EU	EMC Directive
2011/65/EU	RoHS (category 9)
2015/863/EU	Delegated Directive (RoHS III)

Also, the following standards are fulfilled:

EN 61326-1:2013 Electrical equipment for measurement, control and laboratory use - EMC requirements - Part 1: General requirements

EN IEC 63000:2018 Technical documentation for the assessment of electrical and electronic products with respect to the restriction of hazardous substances

Hofheim, 22 May 2024



H. Volz
General Manager



J. Burke
Compliance Manager

11. UK Declaration of Conformity

We, KOBOLD Messring GmbH, Nordring 22-24, 65719 Hofheim, Germany, declare under our sole responsibility that the product:

Relay extension board for MAN-LC Model: ZUB-MANS-KON1 / 2 ...

to which this declaration relates is in conformity with the following UK directives stated below:

S.I. 2016/1091	Electromagnetic Compatibility Regulations 2016
S.I. 2012/3032	The Restriction of the Use of Certain Hazardous Substances in Electrical and Electronic Equipment Regulations 2012

Also, the following standards are fulfilled:

BS EN 61326-1:2013 Electrical equipment for measurement, control and laboratory use. EMC requirements. General requirements

BS EN IEC 63000:2018
Technical documentation for the assessment of electrical and electronic products with respect to the restriction of hazardous substances.



Hofheim, 22 May 2024

H. Volz
General Manager

J. Burke
Compliance Manager