



## Non-Contact Radar Level Transmitter, 80 GHz

- Integrated Design -  
for liquids and solids



measuring  
•  
monitoring  
•  
analysing

NRE-7



- Measuring range: up to 30 m
- Connection: BSP-, NPT-thread male, flanges
- Material connection: PP, PVDF, PTFE
- $p_{\max}$ : 3 bar
- $t_{\max}$ : +80 °C
- Accuracy: up to  $\pm 2$  mm
- Output: 4 ... 20 mA HART®, 2-wire, relay
- Approval: ATEX (Ex ia)

N2



KOBOLD companies worldwide:

AUSTRALIA, AUSTRIA, BELGIUM, BULGARIA, CANADA, CHINA, CZECHIA, FRANCE, GERMANY, GREAT BRITAIN, HUNGARY, INDIA, INDONESIA, ITALY, MALAYSIA, MEXICO, NETHERLANDS, PERU, POLAND, REPUBLIC OF KOREA, SPAIN, SWITZERLAND, THAILAND, TUNISIA, TURKEY, USA, VIETNAM

KOBOLD Messring GmbH  
Nordring 22-24  
D-65719 Hofheim/Ts.  
Head Office:  
+49(0)6192 299-0  
+49(0)6192 23398  
info.de@kobold.com  
www.kobold.com



## Description

The new NRE-7 non-contact radar level transmitters use the most advanced industrial measurement technology, the 80 GHz FMCW radar. The most fundamental advantage of 80 GHz radars compared to lower frequencies (5...12 GHz and 25 GHz) is the smaller antenna size, better focusability, and narrow beam angle. It uses the latest technology for measuring liquids, masses, emulsions, and other chemicals widely used in, for example, the water industry, food industry, energy industry, pharmaceutical industry, and chemical industry, which provides measurement results with millimeter accuracy.

It is also excellent for measuring substances prone to vapor formation and liquids with gas blanket or large-particle bulk solids. In addition to the level, volume, and weight measurement functions, this product family also inherits the open-channel flow measurement functions and the threshold functions to eliminate false and interfering echoes introduced in connection with ultrasonic devices. Since no medium is required for millimeter waves to propagate, it can also be used in a vacuum.

The device can also be operated with HART® compliant KOBOLD NUS-NTB-NRM-SW software.

## Operating Principle

The reflection of the millimeter-waves is highly dependent on the dielectric constant of the medium. Therefore, the measured medium's dielectric constant ( $\epsilon_r$ ) must be over 1.9 for millimeter-wave level measurement. The measurement principle of a level transmitter with a millimeter-waves signal is based on measuring the reflection's time of flight.

The speed of propagation of millimeter-waves signals in the air, gases, and vacuum is almost constant regardless of temperature and medium pressure, so the measured distance does not depend on the physical parameters of the intermediate medium.

The NRE-7 level transmitter is a continuous-wave frequency modulated radar (FMCW) operating at 80 GHz (W-band). The most obvious advantages of 80 GHz radars over lower frequency (5...12 & 25 GHz) radars are smaller antenna size, better focus, and smaller beam angle. A portion of the millimeter-wave continuous wave energy radiated by the level transmitter antenna is reflected from the measured surface, depending on the material to be measured. The distance of the reflecting surface is calculated with high accuracy by the electronics from the frequency shift of the reflected signal and converted into a distance, level, or volume signal by the electronics.

## Features

- 2-wire 80 GHz (W-band) radar
- Measuring range up to 30 m (98.5 ft) for liquids
- Accuracy of  $\pm 2$  mm (0.078")
- Easy to install due to small antenna diameter
- 1", 1½" encapsulated horn antenna
- Integrated design with IP68 protection
- User-friendly threshold management
- Configuration via PC software\*
- Ex variant

## Applications

- For measuring the level of liquids, emulsions, and other media up to 30 m (98.5 ft)
- For large-particle bulk solids
- Storage tanks, chemical tanks, open pits, sumps, wells
- Measurement through a plastic tank roof
- For material prone to vapor formation
- For measuring liquids with a gas blanket
- It can also be used in a vacuum
- Open-channel flow measurement

## Areas of Application

- Water and Wastewater Industry
- Energy industry / Plant utilities
- Food & Beverage
- Pharmaceutical Industry
- Chemical Industry
- Marine applications
- Agriculture
- Construction materials
- Heavy Industry
- Packaging Industry

**Informative  $\epsilon_r$  values**

Butane (C <sub>4</sub> H <sub>10</sub> )	1.4	Ethers	4.4
LP gas	1.6 ... 1.9	Acetic acid (CH <sub>3</sub> COOH)	6.2
Kerosene	2.1	Limestone	6.1 ... 9.1
Crude Oil		Ammonia (NH <sub>3</sub> )	17 ... 26
Diesel Oil		Acetone (C <sub>3</sub> H <sub>6</sub> O)	21
Benzol (C <sub>6</sub> H <sub>6</sub> )	2.2	Ethyl alcohol (C <sub>2</sub> H <sub>5</sub> OH)	24
Gasoline	2.3	Methyl alcohol (CH <sub>3</sub> OH)	33.1
Bitumen	2.6	Glycol (C <sub>2</sub> H <sub>6</sub> O <sub>2</sub> )	37
Carbon disulfide (CS <sub>2</sub> )		Nitrobenzene (C <sub>6</sub> H <sub>5</sub> NO <sub>2</sub> )	40
Clinker	2.7	Glycerin (C <sub>3</sub> H <sub>8</sub> O <sub>3</sub> )	41.1
Resin	2.4 ... 3.6	Water (H <sub>2</sub> O)	80
Cereal Grain	3 ... 5	Sulfuric acid (H <sub>2</sub> SO <sub>4</sub> ) (T = 20 °C [+68 °F])	84

**Basic Concepts and Elements**

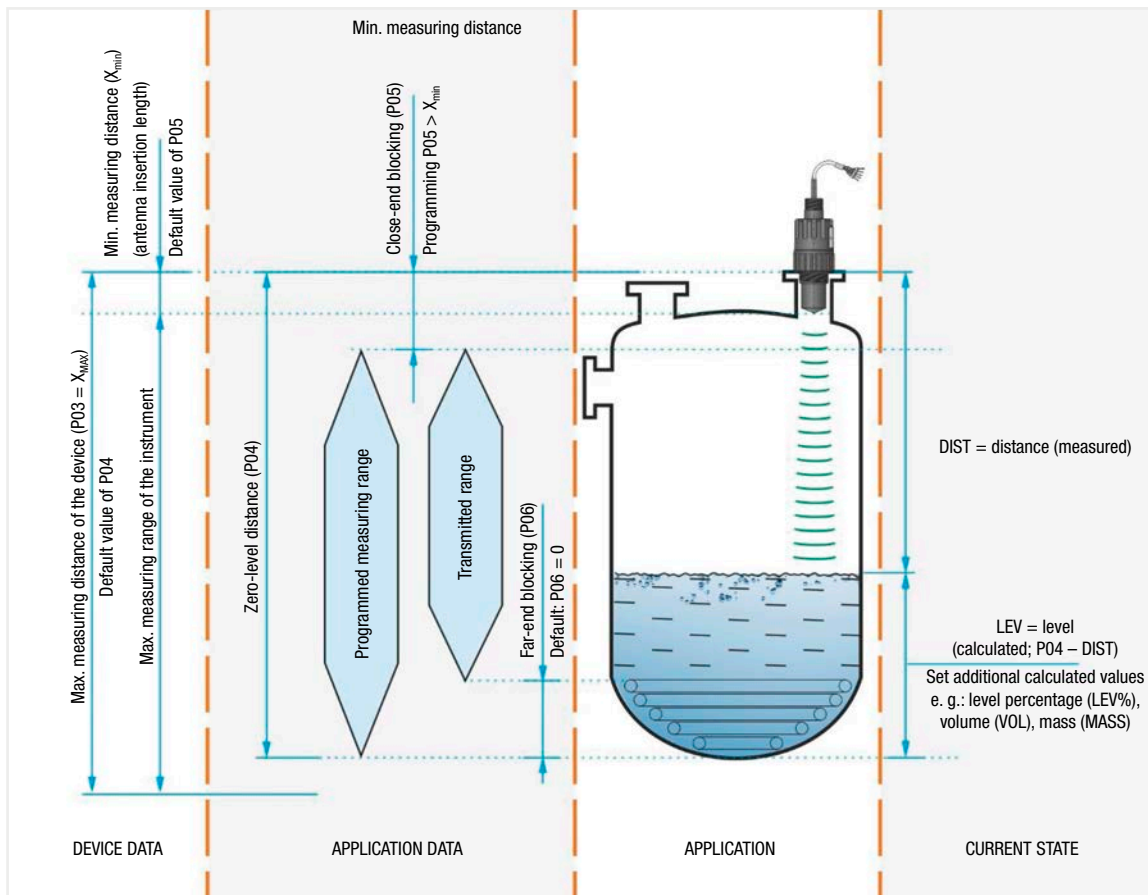



**Technical Details**

Measured values:	Distance; calculated values: level, volume, mass, flow	Antenna diameter <sup>1)</sup> :	1" (25.4 mm), 1½" (38.1 mm)
Signal frequency:	77 ... 81 GHz (W-band)	Antenna material <sup>1)</sup> :	Encapsulated horn antenna (PP / PVDF / PTFE)
Measuring range <sup>1)</sup> :	0 ... 30 m (0 ... 98.5 ft)	Process temperature/ Ambient temperature:	-40 ... +80 °C (-40 ... +176 °F)
Minimum beam angle <sup>1)</sup> :	7°	Process pressure:	-1 ... 3 bar (-14.5 ... 43.5 psi)
Lowest ε <sub>r</sub> of medium <sup>1)</sup> :	1.9	Process connection:	1", 1½" BSP / NPT
Resolution:	0.1 mm (0.039")	Ingress protection:	IP 68
Supply voltage:	12.5 ... 36 V <sub>DC</sub>	Electrical connection:	4 x 0.5 mm <sup>2</sup> shielded Ø6 mm cable x 5 m (up to 30 m); For relay option: 7 x 0.5 mm <sup>2</sup> shielded cable [4x AWG22 shielded Ø0.24" cable x 16.4 ft (up to 98.5 ft); For relay option: 7x AWG22 shielded cable]
<b>Output:</b>		Electrical protection:	Overvoltage Class 1; (Class III [SELV])
Analog:	4 ... 20 mA (3.9 ... 20.5 mA); R <sub>tmax</sub> = (U <sub>s</sub> - 12 V) / 0.02 A	Housing material <sup>1)</sup> :	Plastic (PP / PVDF)
Digital:	Bluetooth® (under development), HART® interface, loop resistance ≥250 Ω	Weight:	approx. 600 g
Relay (optional):	SPDT 30 V / 1 A DC; 48 V / 0.5 A AC		
Service interface:	SAT-504-3 compatible; galvanically isolated; 3.3 V LVDS; max. 100 mA		
Measuring frequency:	~1 s		

<sup>1)</sup> Depending on order code

**Type-dependent Data**

	NRE-710xR25 NRE-710xN25	NRE-710xR40 NRE-710xN40	NRE-720xR40 NRE-720xN40
Dead zone <sup>1)</sup>	0 m		
Maximum measuring range <sup>2)</sup>	10 m (33 ft)		20 m (66 ft)
Accuracy <sup>3)</sup>	±5 mm (±0.197")		±2 mm (±0.078")
Beam angle (-3 dB)	12°	7°	
Antenna insertion length <sup>4)</sup>	56 mm (2.2")	70 mm (2.75")	
Lower process connection	1" BSP / NPT		1½" BSP / NPT
Upper process connection	1" BSP		

<sup>1)</sup> Measured from the tip of the antenna.  
<sup>2)</sup> May be limited in the case of low dielectric constant or non-perpendicular or non-planar media.  
<sup>3)</sup> In the case of an ideal reflecting surface.  
<sup>4)</sup> Measured from the sealing plane of the process connection.



**Linearity Error**

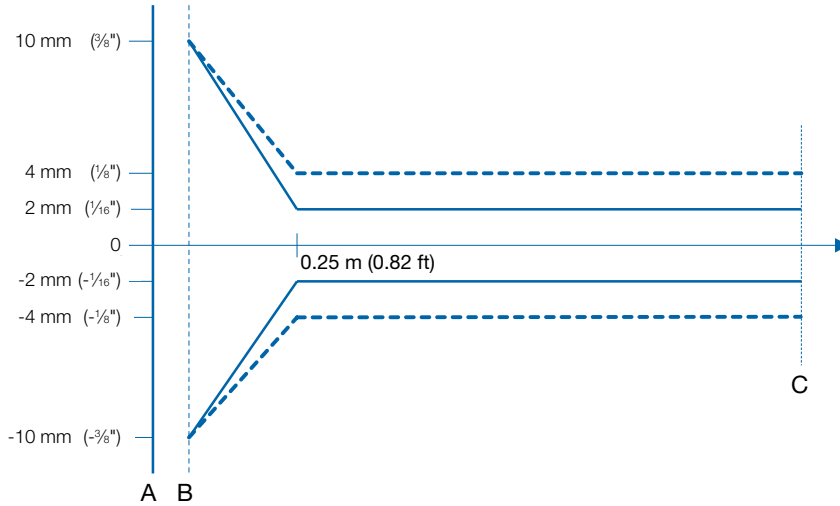

**Legend**

- NRE-710xR25.../ NRE-710xN25.../NRE-710xR40.../ NRE-710xN40...
- NRE-720xR40.../ NRE-720xN40...

- A – Plane of the device's process connection.
- B – The minimum measurement distance ( $X_m$ ), below which the radar cannot measure, due to the insertion length of the antenna.
- C – Maximum measurement distance ( $X_M$ ).

**Ex Information**

**Protection mark, ambient temperature**

Standard Design		
Integrated design NRE-7	Protective labelling	II 1 G Ex ia IIC T5 Ga II 1 D Ex ia IIIC T95°C Da

Standard Design		
Integrated design NRE-7	Ambient temperature	-40°C...+80°C



**Ex Information** (cont'd)

**NRE-7 Integrated Design**

**General Data**

Ex marking (ATEX)	II 1 G Ex ia IIC T5 Ga	II 1 D Ex ia IIIC T95°C Da
Ex power supply, Intrinsic safety data*	U <sub>i</sub> = 30 V, I <sub>i</sub> = 100 mA, P <sub>i</sub> = 0,75 W,	U <sub>i</sub> = 30 V, I <sub>i</sub> = 140 mA, P <sub>i</sub> = 1 W,
	C <sub>i</sub> ≤ 12 nF + 0.12 nF/m cable, L <sub>i</sub> ≤ 238 μH + 0.65 μH/m cable with standard cable 5 m (16.4 ft): C <sub>i</sub> ≤ 12.5 nF, L <sub>i</sub> ≤ 242 μH	
Supply voltage	12 ... 30 V <sub>DC</sub>	

\* in IIB applications, Ex power supply data IIIC can be used

**Temperature Limit Data for ATEX (Ex ia) Approved Models**

Temperature data	Hazardous gas atmosphere	Hazardous dust atmosphere
	Ex ia IIC	Ex ia IIIC
Temperature class	<b>T5</b>	<b>T95°C</b>
Highest ambient temperature	+80 °C (+176 °F)	+80 °C (+176 °F)
Highest surface temperature of the instrument **	+80 °C (+176 °F)	+80 °C (+176 °F)

\*\* Due to conducted or radiated heat transferred by medium, environment or connection.

**Polarisation**

The NRE 80 GHz radar is much less sensitive to installation conditions, both in terms of polarization and clutter sensitivity, due to its narrow and nearly circular beamwidth.

**Background Mapping**

Thanks to its 80 GHz FMCW technology, it is much less sensitive to the presence of clutter than previous generation radars. It now has an easy-to-use, flexible threshold management (NUS-NTB-NRM-SW) that allows echoes from clutter in the tank to be easily masked if necessary. The threshold curve is designed to mask unwanted echoes from the measurement. Echo peaks below the threshold are not included in the evaluation.



**Order Details NRE-7** (Example: NRE-710AR25A0KK0)

Model	Measuring range	Material Antenna/ Housing	Process connection top / bottom
<b>NRE-7</b> = Radar Level Transmitter, 80 GHz, integrated design	<b>10</b> = 10 m <b>20</b> = 20 m <b>30<sup>3)</sup></b> = 30 m	<b>A</b> = PP/ PP <b>B</b> = PVDF/ PVDF <b>T</b> = PTFE/ PVDF	<b>R25</b> = 1" BSP/ 1" BSP (only for range 10 m) <b>N25</b> = 1" NPT / 1" NPT (only for range 10 m) <b>R40</b> = 1½" BSP / 1½" BSP (only for range 10 m/ 20 m) <b>N40</b> = 1½" NPT / 1½" NPT (only for range 10 m / 20 m) <b>R50<sup>3)</sup></b> = 2" BSP/ 1" BSP (only for range 20 m) <b>N50<sup>3)</sup></b> = 2" NPT/ 1" BSP (only for range 20 m) <b>D75<sup>3)</sup></b> = Ø75 mm (2½") / 1" BSP (only for range 30 m)

Output / Display / Approval	Cable length	Option
<b>A0K</b> = 4...20 mA HART® / without / without <b>A0T<sup>3)</sup></b> = 4...20 mA HART® / without / ATEX Ex ta D <b>A0U<sup>3)</sup></b> = 4...20 mA HART® / without / IECEx Ex ta D <b>A0I</b> = 4...20 mA HART® / without / ATEX Ex ia GD <b>A0J</b> = 4...20 mA HART® / without / IECEx Ex ia GD <b>R0K</b> = 4...20 mA HART® + relay / without / without <b>R0T<sup>3)</sup></b> = 4...20 mA HART® + relay / without / ATEX Ex ta D <b>R0U<sup>3)</sup></b> = 4...20 mA HART® + relay / without / IECEx Ex ta D	<b>K<sup>1)</sup></b> = cable length	<b>0</b> = without <b>Y<sup>2)</sup></b> = Special option



<sup>1)</sup> please specify cable length in 1 m steps in clear text (max. 30 m)

<sup>2)</sup> please specify in clear text (not for Ex-version)

<sup>3)</sup> in preparation



Order Details HART® modem

Order no. HART® modem: HARTCOM-0	Order no. HART® modem: HARTCOM-1
with external 24 V <sub>DC</sub> transmitter supply and 250 Ω resistor	Loop Powered 24 V <sub>DC</sub> and 250 Ω integrated resistor
	

Wiring examples

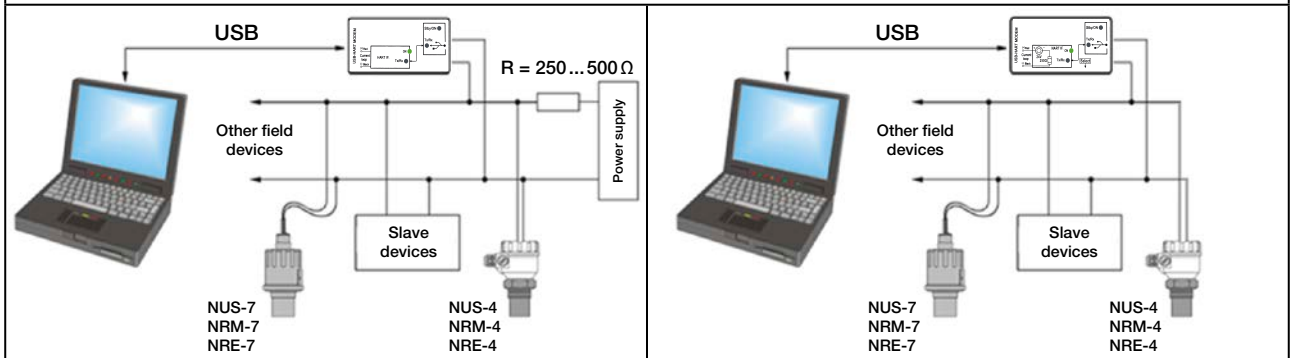

Download of configuration software NUS-NTB-NRM-SW at [www.kobold.com](http://www.kobold.com)



**Order Details ZPF** (Example: ZPF-23)

Model	Standard / Flange Material / Form	Flange type
<p><b>ZPF</b> = Flange made from PP as accessory e.g. for NRE</p>	<p><b>DIN Flanges PN16</b>  <b>2</b> = DN80 PN16  <b>3</b> = DN100 PN16  <b>4</b> = DN125 PN16  <b>5</b> = DN150 PN16  <b>6</b> = DN200 PN16  <b>7</b> = DN250 PN16  <b>8</b> = DN300 PN16  <b>9</b> = DN350 PN16</p> <p><b>FF ANSI flanges, 150 psi</b>  <b>A</b> = 3" FF 150 psi  <b>B</b> = 4" FF 150 psi  <b>C</b> = 5" FF 150 psi  <b>D</b> = 6" FF 150 psi  <b>E</b> = 8" FF 150 psi  <b>Y</b> = 12" FF 150 psi  <b>K</b> = 14" FF 150 psi</p> <p><b>JIS flanges, 10K</b>  <b>G</b> = 80A (as per 10K)  <b>H</b> = 100A (as per 10K)  <b>P</b> = 125A (as per 10K)  <b>R</b> = 150A (as per 10K)  <b>S</b> = 200A (as per 10K)  <b>Z</b> = 300A (as per 10K)  <b>W</b> = 350A (as per 10K)</p>	<p><b>3</b> = For units with 2" BSP process connection  <b>4</b> = For units with 2" NPT process connection  <b>6</b> = For units with 1½" BSP process connection  <b>7</b> = For units with 1½" NPT process connection</p>



**Wiring**

**Color coding of terminals**

- pink** – C1 relay output
- gray** – CC relay output
- blue** – C2 relay output
- white** – I Current loop, supply voltage, and HART® terminal 1 (polarity-independent)
- brown** – I Current loop, supply voltage, and HART® terminal 2 (polarity-independent)
- black** – GND Technical ground and shielding point

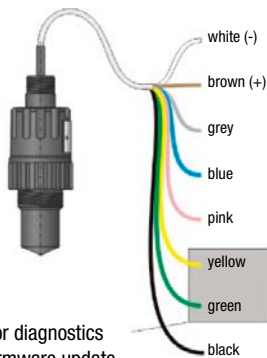
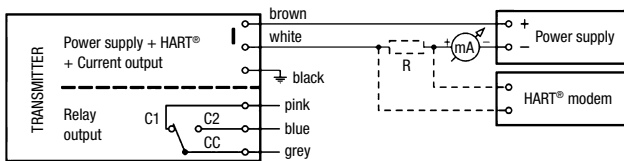

Port for diagnostics and firmware update

**HART® communication**

The output of the device can be used as:

- Current loop output and HART®

The NUS-NTB-NRM-SW program supports the current output mode with HART®. In accordance with the Rosemount Standard, HART® communication can be used between the NRE as a “slave” and the HART® master as a point-to-point connection.

Communication can be implemented as follows:

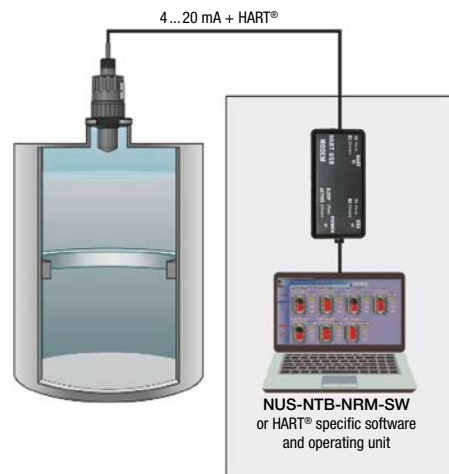

**Dimensions [mm]**

- NRE-710xR25...
- NRE-710xN25...

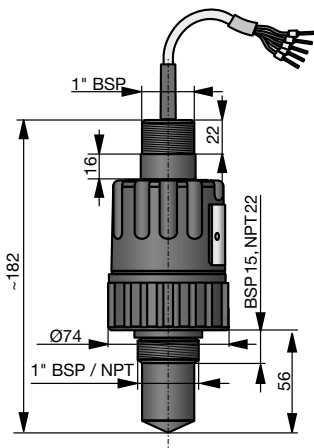

- NRE-7xxxR40...
- NRE-7xxxN40...

