

**Operating Instructions
for
Deep-well Probe**

Model: NTB



1. Contents

1. Contents	2
2. Note	3
3. Instrument Inspection	3
4. Regulation Use	4
5. Operating Principle	4
6. Mechanical Connection	5
7. Electrical Connection	7
8. Maintenance	8
9. Technical Information	9
10. Order Codes	9
11. Dimensions	9
12. Disposal	10
13. EU Declaration of Conformance	11

Manufactured and sold by:

Kobold Messring GmbH
Nordring 22-24
D-65719 Hofheim
Tel.: +49(0)6192-2990
Fax: +49(0)6192-23398
E-Mail: info.de@kobold.com
Internet: www.kobold.com

2. Note

Please read these operating instructions before unpacking and putting the unit into operation. Follow the instructions precisely as described herein.

The instruction manuals on our website www.kobold.com are always for currently manufactured version of our products. Due to technical changes, the instruction manuals available online may not always correspond to the product version you have purchased. If you need an instruction manual that corresponds to the purchased product version, you can request it from us free of charge by email (info.de@kobold.com) in PDF format, specifying the relevant invoice number and serial number. If you wish, the operating instructions can also be sent to you by post in paper form against an applicable postage fee.

Operating instructions, data sheet, approvals and further information via the QR code on the device or via www.kobold.com

The devices are only to be used, maintained and serviced by persons familiar with these operating instructions and in accordance with local regulations applying to Health & Safety and prevention of accidents.

3. Instrument Inspection

Instruments are inspected before shipping and sent out in perfect condition.

Should damage to a device be visible, we recommend a thorough inspection of the delivery packaging. In case of damage, please inform your parcel service / forwarding agent immediately, since they are responsible for damages during transit.

Scope of delivery:

The standard delivery includes:

- Deep-well probe, Model: NTB with connection cable

4. Regulation Use

Any use of the Deep-well probe, model: NTB, which exceeds the manufacturer's specification, may invalidate its warranty. Therefore, any resulting damage is not the responsibility of the manufacturer. The user assumes all risk for such usage.

5. Operating Principle

The immersion probe comprises a measuring cell, two-wire transmitter and special cable with capillary tube. The housing is made out of stainless steel with a pressure-sensitive diaphragm that is protected with a plastic cap. The level signal is determined by the pressure difference between the water column over the probe and atmospheric pressure which is transferred to the probe through the capillary tube. This differential pressure is converted to a 4 to 20 mA analogue signal by the piezo-resistive cell and the fitted electronics.

6. Mechanical Connection

The immersion probe is immersed up to the deepest point into the well or the basin. This is because only the water column above the sensor is measured.



The probe may not fall onto the water surface, but must be immersed carefully, since otherwise the membrane will be destroyed.

Fasten the cable in such a way, so that the probe hangs freely and the capillary and supply pipe are not squeezed together. To anchor it properly, wind the tube three to four times around a pipe having a diameter from 50 to 100 mm and fix the cable-ends with a cable-strap. The cable end should be prepared according to the following diagram.



Moisture must not be allowed to enter the capillary.

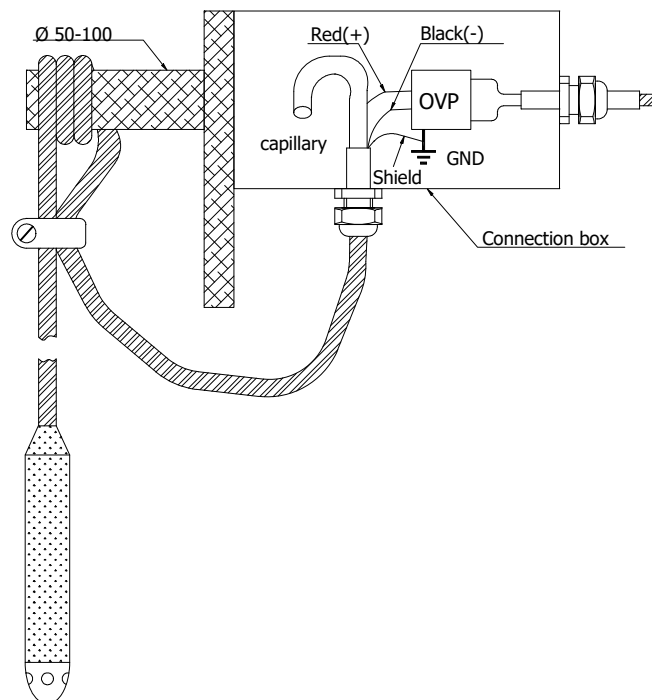

An over-voltage protection (NTB-OVP) should be used with the outdoor-installation. The grounding of the over-voltage protection must be connected to the protective grounding via the shortest path available. Please observe the relevant regulations and safety standards (VDI/VDE).

If the conductor length in the open field is larger than 15 m (outdoors) between transducer and evaluation electronics, an additional over-voltage protection needs to be employed.

To protect sensor against pressure-surges, the immersion probe can be placed inside a pipe.

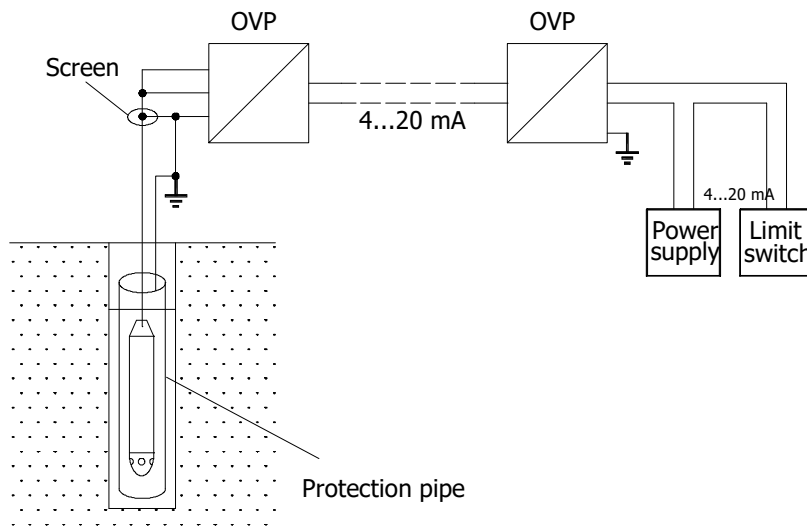

7. Electrical Connection

The sensor and the over-voltage protector should be connected according to the following diagram.

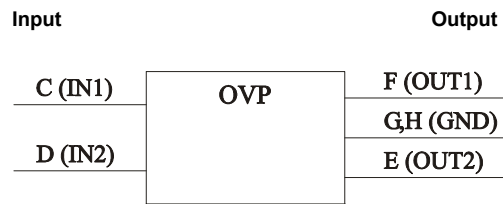
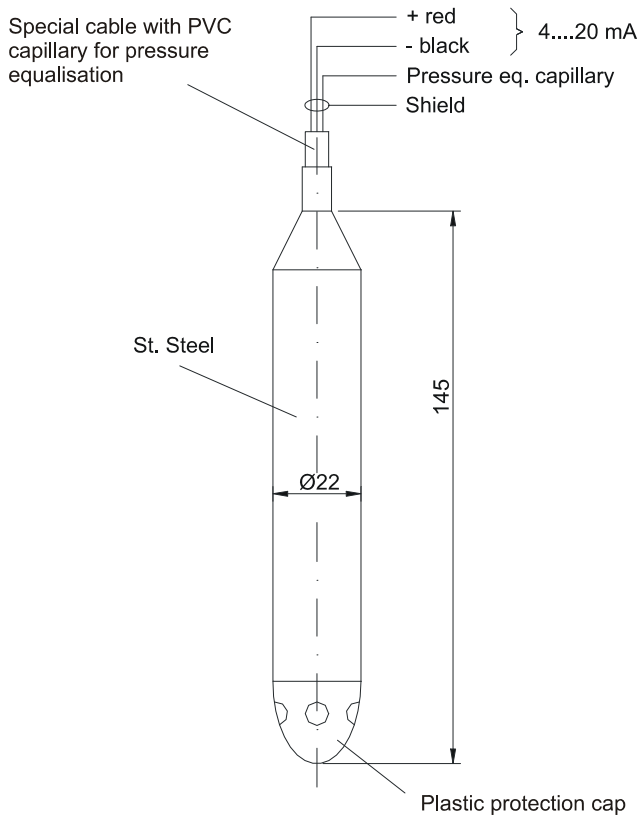

The conductor, on which over-voltage may develop, must be connected to the input terminals of over-voltage protector. The sensor and evaluation-unit must be connected to the output terminals.

8. Maintenance

In case the medium to be measured is not contaminated, NTB units are maintenance-free. If the dirt forms on membrane and needs to be cleaned make sure you do not use any hard cleaning agents. If damaged, repair of membrane is possible only by the manufacturer.

9. Technical Information

Operating instructions, data sheet, approvals and further information via the QR code on the device or via www.kobold.com

10. Order Codes

Operating instructions, data sheet, approvals and further information via the QR code on the device or via www.kobold.com

11. Dimensions

Operating instructions, data sheet, approvals and further information via the QR code on the device or via www.kobold.com

12. Disposal

Note!

- Avoid environmental damage caused by media-contaminated parts
- Dispose of the device and packaging in an environmentally friendly manner
- Comply with applicable national and international disposal regulations and environmental regulations.

Batteries

Batteries containing pollutants are marked with a sign consisting of a crossed-out garbage can and the chemical symbol (Cd, Hg, Li or Pb) of the heavy metal that is decisive for the classification as containing pollutants:

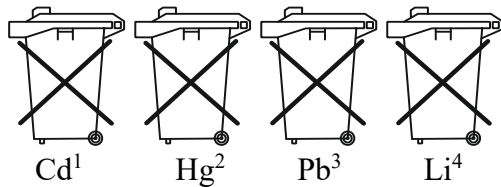

1. „Cd" stands for cadmium
2. „Hg" stands for mercury
3. „Pb" stands for lead
4. „Li" stands for lithium

Electrical and electronic equipment

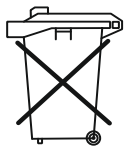

13. EU Declaration of Conformance

We, KOBOLD Messring GmbH, Nordring 22-24, 65719 Hofheim, Germany, declare under our sole responsibility that the product:

Deep-well probe Model: NTB...

to which this declaration relates is in conformity with the following EU directives stated below:

2014/30/EU	EMC Directive
2014/35/EU	Low Voltage Directive
2011/65/EU	RoHS (category 9)
2015/863/EU	Delegated Directive (RoHS III)

Also, the following standards are fulfilled:

EN 61010-1:2011 Safety requirements for electrical equipment for measurement, control and laboratory use - Part 1: General requirements

EN 61326-1:2013 Electrical equipment for measurement, control and laboratory use - EMC requirements - Part 1: General requirements

EN 61326-2-3:2013 Electrical equipment for measurement, control and laboratory use - EMC requirements - Part 2-3: Particular requirements - Test configuration, operational conditions and performance criteria for transducers with integrated or remote signal conditioning

EN 50581:2013 Technical documentation for the assessment of electrical and electronic products with respect to the restriction of hazardous substances

Hofheim, 30 Jan. 2024

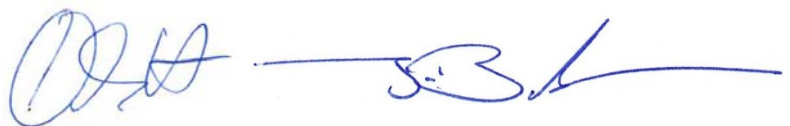

H. Volz
General Manager

J. Burke
Compliance Manager