

# Operating Instructions for Level Sensor

**Model: NGR**



Contents

1 NGR level sensor .....	5
1.1 Principle of operation.....	5
1.2 Safety notes.....	5
1.3 Fields of application .....	5
1.4 Installation conditions .....	6
1.5 Electrical connection .....	9
1.6 Display .....	9
1.7 IO-Link.....	10
1.8 Mounting the coaxial tube.....	10
1.9 Shortening/replacing the probe.....	11
1.10 Mounting the probe rod.....	13
2 Commissioning the NGR.....	14
2.1 Quick commissioning (with factory settings).....	14
2.2 Advanced commissioning.....	14
2.3 Foam commissioning (with factory settings).....	16
3 Configuring the switching outputs .....	18
3.1 Switching hysteresis and window function.....	18
3.2 N/O output with configurable hysteresis .....	19
3.3 N/C output with configurable hysteresis .....	20
3.4 N/O output with window function .....	21
3.5 N/C output with window function .....	22
3.6 N/O output with error signal.....	23
3.7 N/C output with error signal.....	23
4 Configuring the analog output .....	24
4.1 Automatic signal detection.....	24
4.2 Current output 4-20 mA .....	24
4.3 Voltage output 0-10 V.....	24
5 Advanced functions .....	25
5.1 Expert mode .....	25
5.2 Filtering measured values .....	25
5.3 Automated adjustment of the interference limit.....	27
5.4 Selection of evaluation method.....	27
5.5 Testing the configuration .....	27
5.6 Configuring the probe length.....	28
5.7 Teaching in static interference signals .....	28
5.8 Evaluating signal quality.....	29

## Contents

5.9 Changing the coaxial cable length .....	30
5.10 Activating the display lock .....	30
5.11 Selecting the display unit (millimeter/inch) .....	30
5.12 Setting the offset .....	31
5.13 Resetting the calibration.....	32
6 Menu overview .....	32
7 Troubleshooting .....	40
7.1 Error message on the display.....	40
7.2 Operating the display .....	41
7.3 Outputs .....	42
7.4 Behavior.....	42
8 Technical data.....	44
8.1 Features.....	44
8.2 Performance.....	44
8.3 Reference conditions.....	45
8.4 Measurement accuracy.....	46
8.5 Mechanics/materials.....	48
8.6 Electrical connection values.....	48
8.7 Environmental conditions.....	49
8.8 Dimensional drawings .....	50
8.9 Factory settings.....	52
9 Order details.....	53
10 Maintenance.....	54
11 Returning the level sensor .....	54
12 Disposal .....	54
13 Medium list .....	54
Appendix 1 Medium list.....	55
Appendix 2 Parameter table.....	61
14 IO Link Manufacturer's Declaration.....	65
15 EU Declaration of Conformance.....	66
16 UK Declaration of Conformance.....	67



---

The instruction manuals on our website [www.kobold.com](http://www.kobold.com) are always for currently manufactured version of our products. Due to technical changes, the instruction manuals available online may not always correspond to the product version you have purchased. If you need an instruction manual that corresponds to the purchased product version, you can request it from us free of charge by email ([info.de@kobold.com](mailto:info.de@kobold.com)) in PDF format, specifying the relevant invoice number and serial number. If you wish, the operating instructions can also be sent to you by post in paper form against an applicable postage fee.

---

# 1 NGR Sensor

## 1 NGR level sensor

### 1.1 Principle of operation

The NGR uses TDR (Time Domain Reflectometry) technology. This is a process to determine transit times of electromagnetic waves. The sensor electronics generate a low-energy electromagnetic pulse, which is linked to and runs along the probe. If this pulse strikes the surface of the liquid to be measured, a portion of the pulse is reflected there and is conducted back up along the probe path to the electronics, which then calculate the level based on the time difference between the sent and the received pulse. The sensor can output this level as a continuous measured value (analog output) and can also derive two or four freely positionable switching points from it (switching outputs).

### 1.2 Safety notes

- Read the operating instructions prior to commissioning.
- These operating instructions are valid for devices from firmware version 4.00.
- Connection, mounting, and setting may only be performed by trained specialists.
- The NGR is not a safety component under the EU Machinery Directive.
- Observe national safety and work safety regulations.
- Repairs may only be carried out by the manufacturer. Altering or tampering with the device is not permitted.
- Wiring work and the opening and closing of electrical connections may only be carried out when the power is switched off.
- The radiated power is far lower than that from telecommunication equipment. According to current scientific research, the operation of this device can be classified as safe and nonhazardous.
- Incorrect handling or improper use can lead to malfunctions in your application.

### 1.3 Fields of application

The innovative TDR technology enables reliable level measurement which is largely application-independent. The NGR is suitable for both continual level measurement and limit level detection in nearly all liquids.

It is not affected by changes in the properties of the liquids to be measured. The NGR can be used in metal containers or bypass/immersion pipes. A coaxial tube is required for use in plastic containers.

# 1 NGR level sensor

## 1.4 Installation conditions

The NGR is mounted vertically from above into the container or bypass, using its process connection. The NGR level sensor has a G 3/4 or 3/4" NPT threaded connection. Observe a minimum connection diameter in accordance with the following Diagrams 1 and 3. The NGR must be installed so that after mounting there is sufficient distance to other tank components (e.g., supply tubes, other measurement devices), the container wall, or the container bottom. Minimum distances are also described in Diagrams 1 and 3. The NGR can also be used in a metal immersion pipe or bypass. The installation conditions are shown in Diagram 2. Ensure that there is a good metallic connection between the NGR measuring device and the tank bypass. When operating the sensor, ensure that the ambient temperature is not above or below the limits. Insulating the sensor housing is not permitted for tanks with hot media. When positioning the device, ensure that the sensor is not directly exposed to the filling flow. The sensor housing can be rotated 360°, allowing for the cable outlet to be positioned freely.

### Installation in a container

**Note:** The distances are the same for the sensor with remote amplifier.

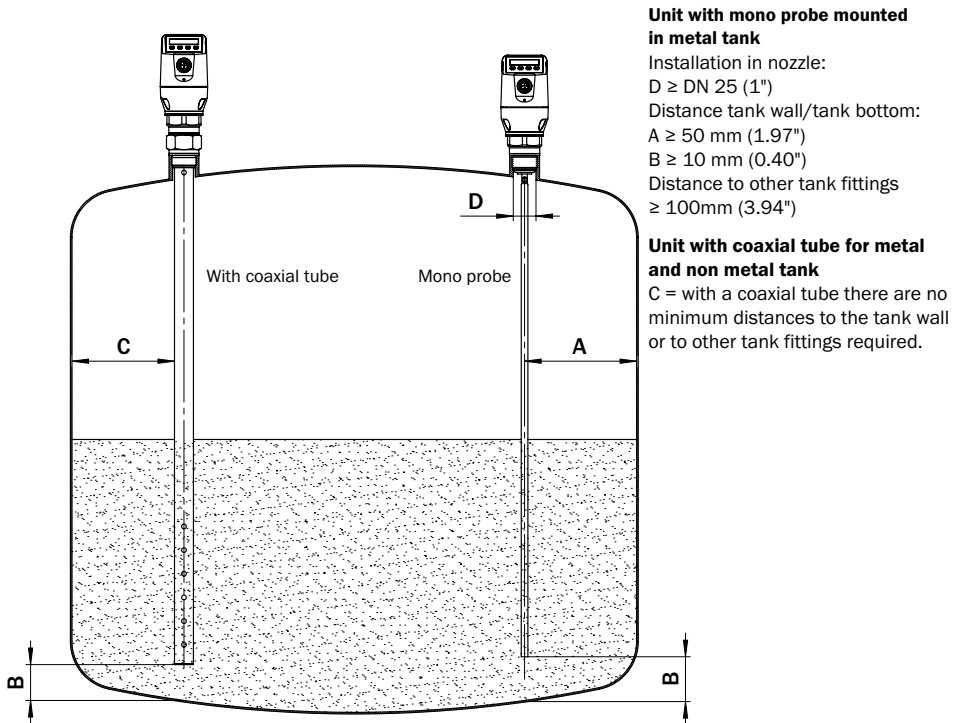

Diagram 1

# 1 NGR level sensor

Installation in a metal immersion tube or metal bypass

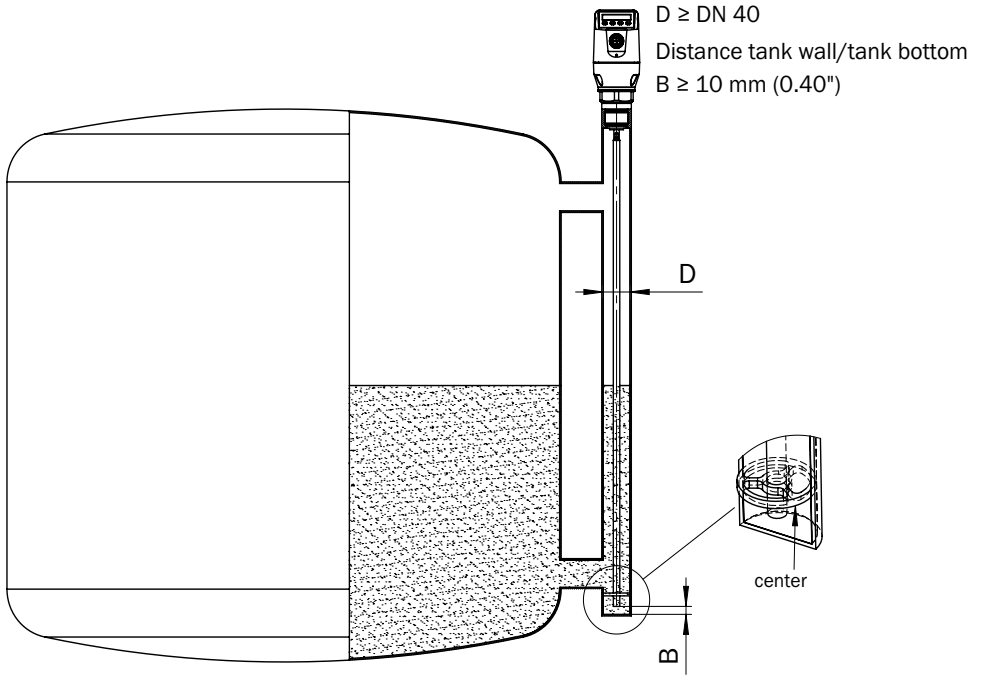
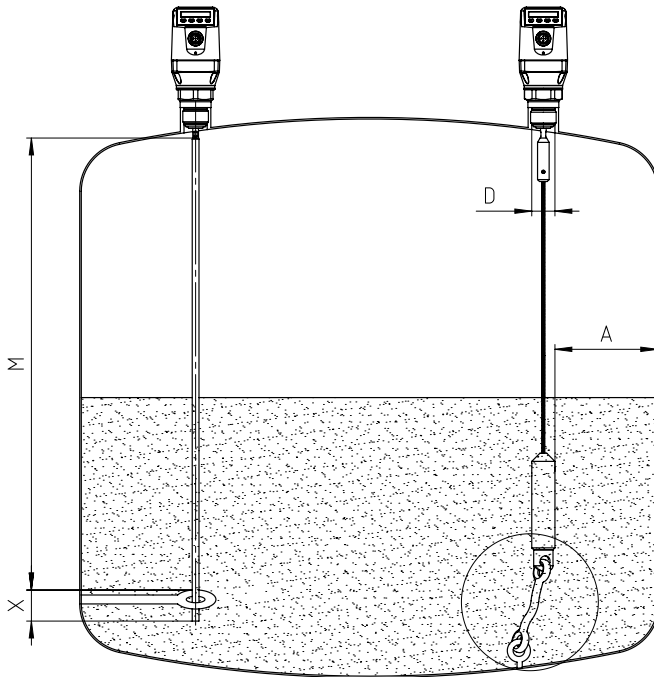

Diagram 2

Centering: To prevent contact between the probe and the bypass pipe during oscillations, the probe should be centered according to its length and depending on the diameter of the bypass pipe. To do this, it is necessary to insert one or two centering pieces.

# 1 NGR level sensor



Mono probe fixing  
M = Measuring range  
X = No measuring possible  
in this area

## Rope probe mounted in metal tank

Installation in nozzle:

$D \geq \text{DN } 25 \text{ (1")}$

Distance tank wall/tank bottom:

$A \geq 50 \text{ mm (1.97")}$

Distance to other tank fittings

$\geq 100 \text{ mm (3.94")}$

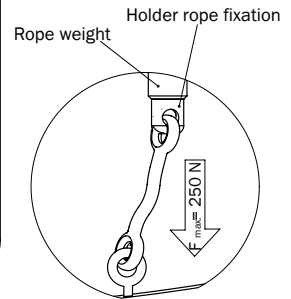

Diagram 3

Tank welds can affect the measurement accuracy.

# 1 NGR level sensor

## 1.5 Electrical connection

The sensor is connected using a pre-assembled female cable connector with 1 x M12 plug connector (5 or 8-pin). With the power switched off, plug the female cable connector into the sensor and screw it tight. Connect the cable according to its function. After the supply voltage has been applied, the sensor carries out a self-test. Once installed, the sensor is ready for operation on completion of the self-test (< 5 s). The display shows the current measured value.

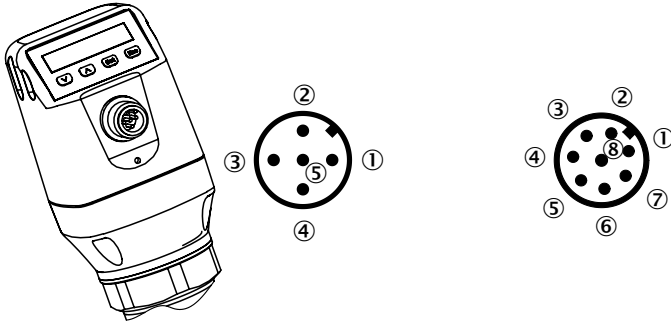

- ① L: Supply voltage, brown
- ② Q<sub>A</sub>: Analog current/voltage output, white
- ③ M: Ground, reference potential for current/voltage output, blue
- ④ C/Q<sub>1</sub>: Switching output 1, PNP, IO Link communication, black
- ⑤ Q<sub>2</sub>: Switching output 2, PNP/NPN, gray

- ① L: Supply voltage
- ② Q<sub>2</sub>: Switching output 2, PNP/NPN
- ③ M: Ground, reference potential for current/voltage output
- ④ C/Q<sub>1</sub>: Switching output 1, PNP/IO Link communication
- ⑤ Q<sub>3</sub>: Switching output 3, PNP/NPN
- ⑥ Q<sub>4</sub>: Switching output 4, PNP/NPN
- ⑦ Q<sub>5</sub>: Analog current/voltage output
- ⑧ No function

The wire colors for 8-pin cables are not uniform. Always note the pin assignment of the sensor.

## 1.6 Display

All lengths specified (in mm) in the menu refer to the end of the probe or for a configured offset (see “5.4 Configuring the probe length”) on the tank bottom. You can access the menu by pressing the Set pushbutton for at least three seconds.

### Variants with two switching outputs

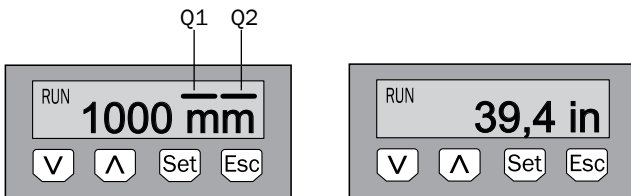

**Note:** The statuses of the switching outputs are indicated in millimeters by bar graphs above the unit. This display is not available when inches are selected as the unit.

### Variants with four switching outputs

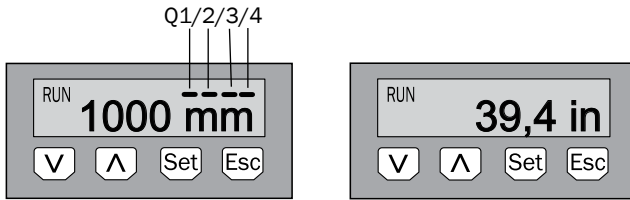

**Arrow pushbuttons:**

For navigating in the menu and changing values

**Set pushbutton:**

For saving and confirming

**Esc pushbutton:**

For exiting the operating menu step-by-step

### 1.7 IO-Link

The IO-Link parameter table for NGR device can be found in Appendix 2.

To ensure that the IO-Link device can be operated correctly on the connected IO-Link master, it is necessary to install the device description file matching the device.

The device description files (IODD) are available in the IODDfinder, [ioddfinder.io-link.com](http://ioddfinder.io-link.com). Further information on IO-Link is available on the homepage [www.io-link.com](http://www.io-link.com).

### 1.8 Mounting the coaxial tube

Retrofitting of coaxial probe

Mount the spacer on the rod probe (first one at approx. 500 mm from thread, then every 500 mm) and make 2 to 3 punch marks on both sides of each spacer on the rod probe. Do not pull the spacers over the punch marks.

Punch marks prevent sliding of the spacer in both directions.

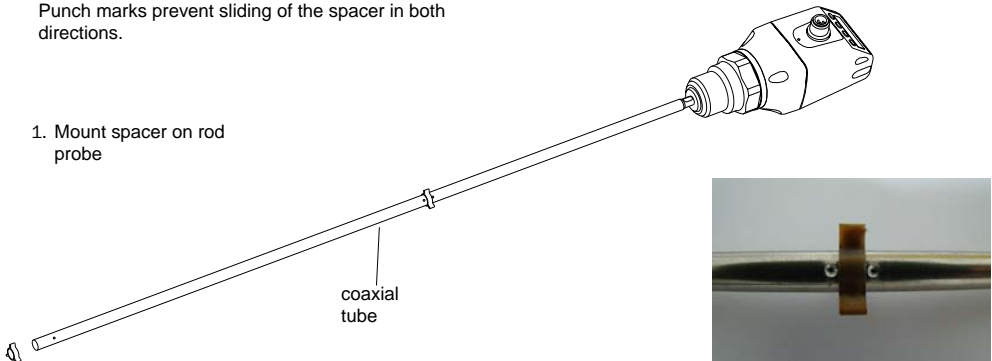

1. Mount spacer on rod probe

# 1 NGR level sensor

## 2. Screw coaxial probe

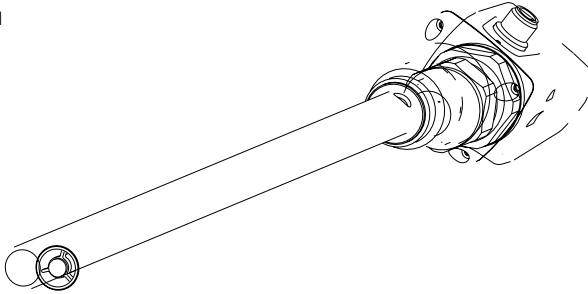

### 1.9 Shortening or replacing the probe rod/cable probe

If the probe rod or cable probe\* is too long for the application, it can be shortened to the container height. In this case, you should not shorten the probe beyond its minimum length of 100 mm.

Procedure: Shorten the probe rod or cable probe\* as desired. Set the new probe length in the NGR as described in Chapter "5.6 Configuring the probe length". Ensure that this correction corresponds to the probe length, because an incorrect value in the *Length* menu has a direct effect on measurement accuracy and can lead to faults. The probe rod or cable probe\* can be replaced on the NGR. Use a suitable tool. If the system experiences strong vibrations, secure the probe with thread locker.

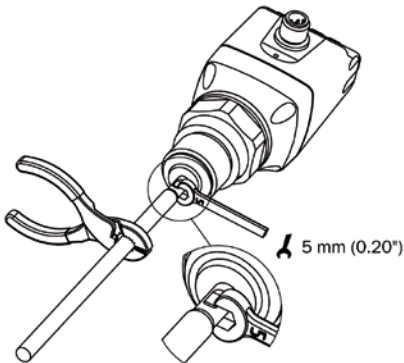

# 1 NGR level sensor

## Shortening the cable probe\*

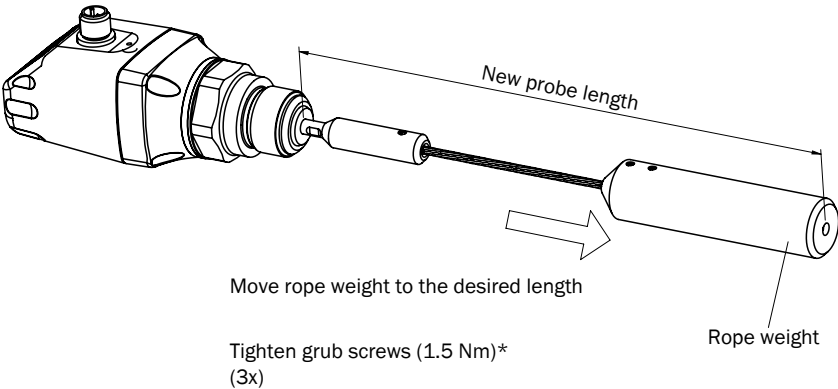
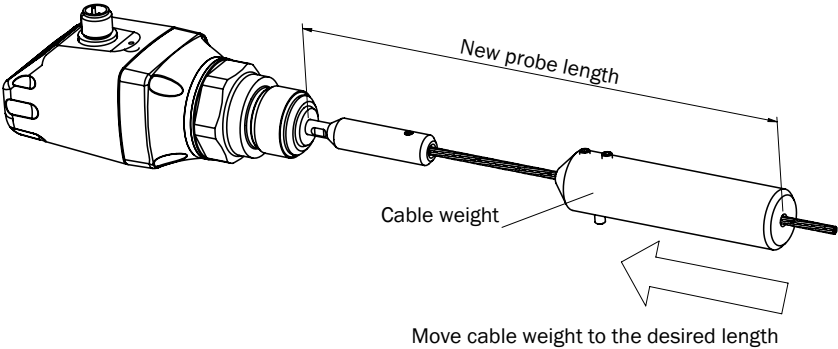
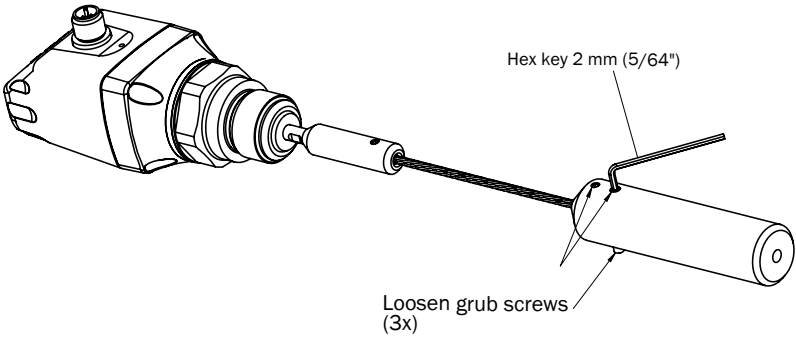

\*We recomend to use thread locking fluid to secure the grub screws

# 1 NGR level sensor

## 1.9 Mounting the probe rod

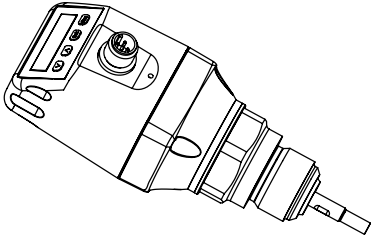

With the NGR, the probe rod can be modified by the customer. The specifications for the probe rod should be as follows:

- Probe rod diameter: 7 mm to 8 mm
- Probe rod female thread: M5
- Female thread length: min. 10 mm
- Material: Stainless steel

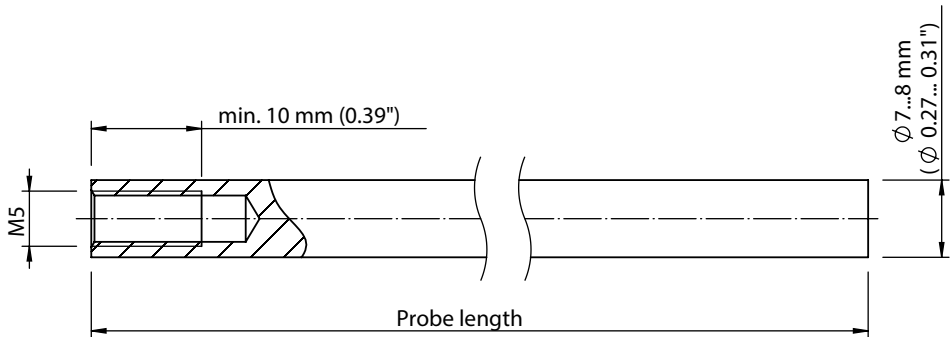

- Total probe length: 100 mm to 4,000 mm
- Total probe length = 15 mm + probe rod length

Set the total probe length as described in Chapter “5.4 Configuring the probe length”. The *EXPR1-Config-Length* menu is password protected. If the system experiences strong vibrations, secure the probe with thread locker.

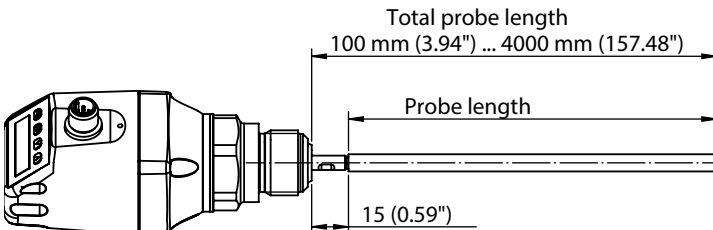

### 2 Commissioning the NGR

#### 2.1 Quick commissioning (with factory settings)

Quick commissioning is used in applications under reference conditions (see Chapter 1.4 "Installation conditions").

The following information applies:

- Use in metallic containers or immersion/bypass pipes
- Use in plastic tanks with a coaxial tube (see Chapter "10 Accessories")
- Situations where the liquid to be measured has a DK value of  $> 5$  (see Chapter 14 "Medium list")

#### Commissioning

1. Mount the sensor according to the installation conditions (see Chapter 1.4 "Installation conditions" and 1.7 "Mounting the coaxial tube").
2. The container must be empty or the level must be below the end of the probe (see page 5 Installation in a container).
3. Log in to expert mode, see chapter 5.1 Expert mode.
4. After mounting, launch the *AutCal* menu item.
  - Press and hold the Set pushbutton for at least 3 secs.
  - Use the Set pushbutton to confirm the *AutCal* menu item and then use it again to confirm the security question *Ok?*.
  - The *AutCal* function is confirmed with *!CalOK*.
5. Configure the outputs (see Chapter 3 "Configuring the switching outputs" and Chapter 4 "Configuring the analog output").

**Note:** If the *AutCal* function has been confirmed with *!NoSig*, relaunch *AutCal*.

If you are encountering problems, see Chapter 7 "Troubleshooting".

#### 2.2 Advanced commissioning

Advanced commissioning is required when quick commissioning is not sufficient or if one of the following situations applies:

- The liquid to be measured has a DK value of  $< 5$  (see Chapter 14 "Medium list")
- There are tank components which can interfere with the measurement signal
- There are extreme ripples on the surface of the liquid
- There are variations in the installation conditions (see Chapter 1.4 "Installation conditions")

#### Commissioning

1. Mount the sensor according to the installation conditions (see Chapter 1.4 "Installation conditions" and 1.7 "Mounting the coaxial tube")
2. Log into expert mode (see Chapter 5.1 "Expert mode")

## 2 Commissioning the NGR

### 3. Select the measuring mode

- Access the *EXPRT-CONFIG-MeasMd* menu using the arrow and Set pushbuttons
- HiSpd: max. length = 2,005 mm, response time < 400 ms
- HiAcc: max. length = 6,005 mm, response time < 2,800 ms, more stable measured values, recommended for liquids with low DK values and where TrsHld is < 70

### 4. Static sources of interference in the tank

- Static sources of interference in the tank generated by tubes, beams, couplings, or a cleaning ball are taught into the system as standard.
- Access the *EXPRT-CONFIG-CalRng* menu using the arrow and Set pushbuttons.
- The following information applies:
  - Teach-in depth starts from the NGR process connection ▫  
Teach-in depth should cover all interference signals
  - Maximum teach-in depth (recommended) = probe length
- Set the value range between 95 and 6,005 mm

### 5. Run the *AutCal* function

- Access the *AutCal* menu using the arrow and Set pushbuttons.
- **The following information applies: The probe must not be covered with liquid in the *CalRng* set in step 4 (teach-in depth + 200 mm).**
- Use the Set pushbutton to confirm the *AutCal* menu item and then use it again to confirm the security question *Ok?*
- The *AutCal* function is confirmed with *!CalOK*.

### 6. Analyze the signal quality

- The signal quality can be analyzed when the device is installed (“5.8 Evaluating signal quality”)
- In the event of problems:
  - Reduce the value in the *EXPRT-CONFIG-TrsHld* menu
  - Set the parameter in the *EXPRT-CONFIG-MeasMd* menu to *HiAcc*
  - Switch on the filter in the *Set filters* menu
  - Reduce the parameter in the *EXPRT-CONFIG-MaxCol* menu

### 7. Configure the filter (see Chapter “5.2 Filtering measured values”)

### 8. Maximum change of level/plausibility check (see Chapter “5.2 Filtering measured values”)

### 9. Configure the outputs (see Chapter 3 "Configuring the switching outputs" and “4 Configuring the analog output”)

#### Notes

- Please use the foam commissioning instructions for applications with foam.
- The sensor automatically quits expert mode after 5 minutes of inactivity on the display.
- Configuration (*AutCal*) does not take place in the following processes:
  - Changing the probe length
  - Changing the measuring mode
  - Changing the teach-in depth

If you are encountering problems, see Chapter 7 "Troubleshooting".

## 2 Commissioning the NGR

### 2.3 Foam commissioning (with factory settings)

For use in applications with a significant buildup of foam.

#### **Performing foam calibration**

1. Mount the sensor according to the installation conditions (see Chapter 1.4 "Installation conditions" and 1.7 "Mounting the coaxial tube")
2. Log into expert mode (see Chapter 5.1 "Expert mode")
3. Empty the tank completely
  - The probe rod must be completely free from medium and foam.
  - Buildup must be removed from the probe.
  - The end of the probe must not be fixed to the bottom of the tank.
4. Select the measuring mode
  - Access the *EXPRT-CONFIG-MeasMd* menu using the arrow and Set pushbuttons, and configure to *HiAcc*.
5. Select mode
  - Access the *EXPRT-Config-Mode* using the arrow and Set pushbuttons, and configure to Foam.
6. Perform empty calibration
  - Access the *EXPRT-FOAM-CalEmp* menu using the arrow and Set pushbuttons.
  - *!CalOk*: proceed to step 7.
  - *!faild*: Ensure that the tank is empty and repeat step 6.
7. Fill with medium (without foam) until the probe is covered by at least 200 mm. The maximum level must remain 200 mm from the process connection, however.
8. Run *EXPRT-Foam-CalMed*
  - *!CalOk*: Everything in working order, proceed to step 9
  - *!faild*: Carry out step 8 againThe display must now show a valid measured value.
9. Check the foam calibration in *EXPRT-Foam-FomSta*
  - active: Foam commissioning was completed successfully.
  - inactive: Commissioning unsuccessful. Please repeat the process.

## 2 Commissioning the NGR

---

### Notes

- Measurement deviation can be higher
- Signal quality 1 and 2 are not counted
- The sensor automatically quits expert mode after 5 minutes of inactivity on the display.
- Configuration (foam teach) does not take place in the following processes:
  - Changing the probe length
  - Changing the measuring mode
  - Changing the teach-in depth
  - Running *AutCal*

If you are encountering problems, see Chapter 7 "Troubleshooting".

## 3 Configuring the switching outputs

### 3 Configuring the switching outputs

#### 3.1 Switching hysteresis and window function

Depending on 2 or 4 output variants

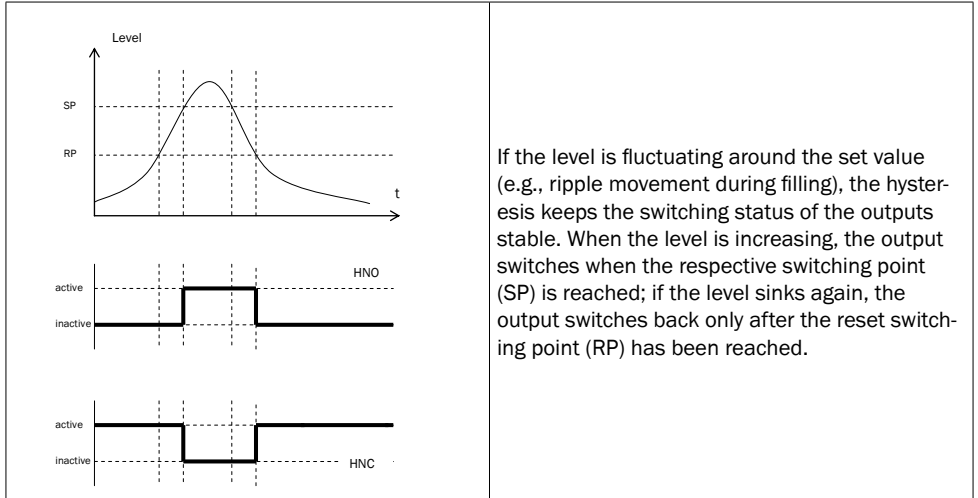

Depending on 2 or 4 output variants

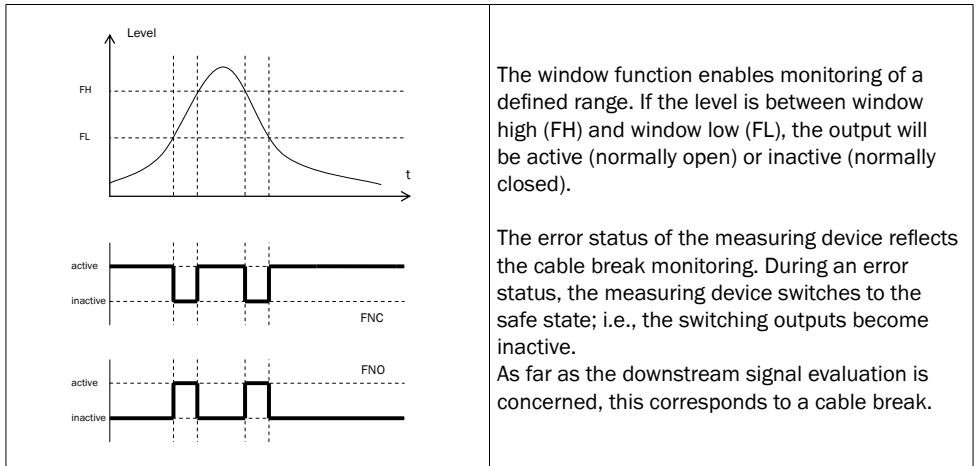

### 3 Configuring the switching outputs

#### 3.2 N/O output with configurable hysteresis

##### Applications

- Dry run protection
- Empty signal

##### Configuration

- Configure the Qx switching output as normally open
  - Set the parameter in the QxMENU-OUx menu to Qx\_Hno
- Set the switching point
  - Set the value in the QxMENU-SPx menu to level in mm (e.g., 500 mm)
- Set the reset point
  - Set the value in the QxMENU-RPx menu to level in mm (e.g., 450 mm)
- Select the electrical property [NPN/PNP/DRV (push/pull)]
  - Select the parameter in the QxMENU-TYPx menu
  - The following information applies:
    - Qx-PNP = Switching output in PNP circuit
    - Qx-NPN = Switching output in NPN circuit
    - Qx-Drv = Switching output in push/pull function
- Switching output behavior

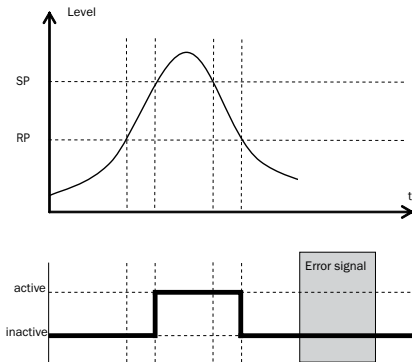

Switching output		PNP	NPN	DRV	Error status
Normally open/HNO	active	Uv	0 V	Uv (PNP switched)	inactive
	inactive	0 V <sup>1)</sup>	Uv <sup>2)</sup>	0 V (NPN switched)	

<sup>1)</sup> Pulldown only

<sup>2)</sup> Pullup only

## 3 Configuring the switching outputs

### 3.3 N/C output with configurable hysteresis

#### Applications

- Overfill protection
- Full signal

#### Configuration

- Configure the Qx switching output as normally closed
  - Set the parameter in the QxMENU-OUx menu to Qx\_Hnc
- Set the switching point
  - Set the value in the QxMENU-SPx menu to level in mm (e.g., 500 mm)
- Set the reset point
  - Set the value in the QxMENU-RPx menu to level in mm (e.g., 450 mm)
- Select the electrical property [NPN/PNP/DRV (push/pull)]
  - Select the parameter in the QxMENU-TYPx menu
  - The following information applies:
    - Qx-PNP = Switching output in PNP circuit
    - Qx-NPN = Switching output in NPN circuit
    - Qx-Drv = Switching output in push/pull function

#### Switching output behavior

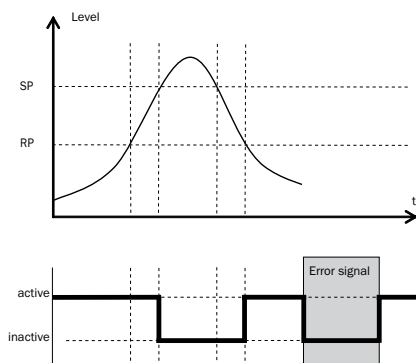

Switching output		PNP	NPN	DRV	Error status
Normally closed/HNC	active	Uv	0 V	Uv (PNP switched)	inactive
	inactive	0 V <sup>1)</sup>	Uv <sup>2)</sup>	0 V (NPN switched)	

<sup>1)</sup> Pulldown only

<sup>2)</sup> Pullup only

## 3 Configuring the switching outputs

### 3.4 N/O output with window function

#### Application

The critical filling level for the application is within the FHx and FLx window thresholds.

#### Configuration

- Configure the Qx switching output as normally open
  - Set the parameter in the QxMENU-OUx menu to Qx\_Fno
- Set the switching point
  - Set the value in the QxMENU-FHx menu to level in mm (e.g., 500 mm)
- Set the reset point
  - Set the value in the QxMENU-FLx menu to level in mm (e.g., 400 mm)
- Select the electrical property [NPN/PNP/DRV (push/pull)]
  - Select the parameter in the QxMENU-TYPx menu
  - The following information applies:
    - Qx-PNP = Switching output in PNP circuit
    - Qx-NPN = Switching output in NPN circuit
    - Qx-Drv = Switching output in push/pull function

#### Switching output behavior

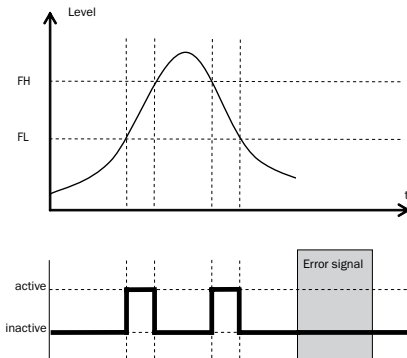

Switching output		PNP	NPN	DRV	Error status
Normally open/FNO	active	Uv	0 V	Uv (PNP switched)	inactive
	inactive	0 V <sup>1)</sup>	Uv <sup>2)</sup>	0 V (NPN switched)	

<sup>1)</sup> Pulldown only

<sup>2)</sup> Pullup only

## 3 Configuring the switching outputs

### 3.5 N/C output with window function

#### Application

The critical filling level for the application is outside the FHx and FLx window thresholds.

#### Configuration

- Configure Qx the switching output as normally closed
  - Set the parameter in the QxMENU-OUx menu to Qx\_Fnc
- Set the switching point
  - Set the value in the QxMENU-FHx menu to level in mm (e.g., 500 mm)
- Set the reset point
  - Set the value in the QxMENU-FLx menu to level in mm (e.g., 400 mm)
- Select the electrical property [NPN/PNP/DRV (push/pull)]
  - Select the parameter in the QxMENU-TYPx menu
  - The following information applies:
    - Qx-PNP = Switching output in PNP circuit
    - Qx-NPN = Switching output in NPN circuit
    - Qx-Drv = Switching output in push/pull function

#### Switching output behavior

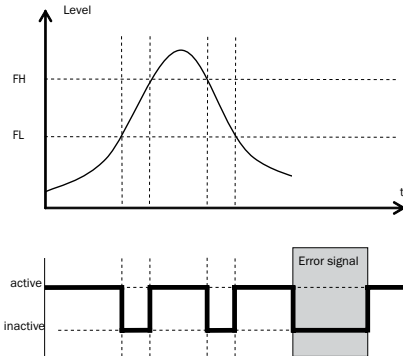

Switching output		PNP	NPN	DRV	Error status
Normally closed/FNC	active	U <sub>v</sub>	0 V	U <sub>v</sub> (PNP switched)	inactive
	inactive	0 V <sup>1)</sup>	U <sub>v</sub> <sup>2)</sup>	0 V (NPN switched)	

<sup>1)</sup> Pulldown only

<sup>2)</sup> Pullup only

### 3.6 N/O output with error signal

#### Application

If there is an error message at the NGR, this can be transferred using a switching contact.

#### Configuration

- Configure the Qx switching output as normally open
  - Set the parameter in the *QxMENU-OUx* menu to Qx\_Eno
- Select the electrical property [NPN/PNP/DRV (push/pull)]
  - Select the parameter in the *QxMENU-TYPx* menu
  - The following information applies:
    - Qx-PNP = Switching output in PNP circuit
    - Qx-NPN = Switching output in NPN circuit
    - Qx-Drv = Switching output in push/pull function

### 3.7 N/C output with error signal

#### Application

If there is an error message at the NGR, this can be transferred using a switching contact.

#### Configuration

- Configure the Qx switching output as normally closed
  - Set the parameter in the *QxMENU-OUx* menu to Qx\_Enc
- Select the electrical property [NPN/PNP/DRV (push/pull)]
  - Select the parameter in the *QxMENU-TYPx* menu
  - The following information applies:
    - Qx-PNP = Switching output in PNP circuit
    - Qx-NPN = Switching output in NPN circuit
    - Qx-Drv = Switching output in push/pull function

### 4 Configuring the analog output

#### 4.1 Automatic signal detection

The NGR can automatically detect which signal is required using the connected output load (see Chapter 9 "Technical data").

The following information applies:

- 4 mA to 20 mA < 500 ohms at  $U_v > 15$  V
- 4 mA to 20 mA < 350 ohms at  $U_v > 12$  V
- 0 V to 10 V > 750 ohms at  $U_v \geq 14$  V

#### Configuration

- Access the *QAMENU-TYP* menu using the arrow and Set pushbuttons.
- Set the *QAMENU-TYP* menu to *Auto?*
- Note: Automatic signal detection is only active when the device is switched on for the first time. After this the function can be activated in the *QAMENU-TYP* menu with *Auto?* again.

#### 4.2 Current output 4-20 mA

#### Configuration

- Set upper limit value (20 mA)
  - Set the value in the *QAMENU-QAHIGH* menu to level in mm (e.g., 500 mm)
- Set lower limit value (4 mA)
  - Set the value in the *QAMENU-QALOW* menu to level in mm (e.g., 10 mm)
- Invert signal
  - The analog signal can be inverted in the *QAPOL* menu
  - Set the parameter in the *QxMENU-QAPOL* menu to *QA-INV*
    - *QA-NRM* = Analog output signal as configured
    - *QA-INV* = Analog output signal is inverted; *QAHIGH* 4 mA and *QALOW* 20 mA
- Select electrical signal
  - Set the parameter in the *QxMENU-QATYP* menu to 4–20 mA

#### 4.3 Voltage output 0-10 V

#### Configuration

- Set upper limit value (10 V)
  - Set the value in the *QAMENU-QAHIGH* menu to level in mm (e.g., 500 mm)
- Set lower limit value (0 V)
  - Set the value in the *QAMENU-QALOW* menu to level in mm (e.g., 10 mm)
- Invert signal
  - The analog signal can be inverted in the *QAPOL* menu
  - Set the parameter in the *QxMENU-QAPOL* menu to *QA-INV*
    - *QA-NRM* = Analog output signal as configured
    - *QA-INV* = Analog output signal is inverted; *QAHIGH* 0 V and *QALOW* 10 V
- Select electrical signal
  - Set the parameter in the *QxMENU-QATYP* menu to 0–10 V

### 5 Advanced functions

#### 5.1 Expert mode

Expert mode must first be set to activate special functions.

##### **Logging into expert mode**

- Access the PASSW menu using the arrow pushbuttons
- Enter password 000537 (NGR on mobile device keypad / L=5 / F=3 / P=7). If an incorrect password is entered or the device is switched off, expert mode is locked again.

#### 5.2 Filtering measured values

##### **Activating filtering**

- Smoothing of the measured value; e.g., in the case of ripples on level surfaces For fast level changes, the average of the measured values over X seconds is indicated.
- Set the parameter in the *Filter* menu
- The possible values are Off, 400 ms, 600 ms, 1,000 ms, 1,400 ms, 2 s, 5 s, 10 s

##### **Maximum change of level (plausibility check)**

- For applications that cause the level to jump on the NGR due to strong interference. Entry for the maximum level dynamic in the application or the maximum permissible change rate of the level.
- Log into expert mode (see Chapter 5.1 "Expert mode")
- Reduce the parameter in the *EXPRT-CONFIG-MaxCol* menu
- AnySpd (50 cm/s) (default), 10 cm/s, 5 cm/s, 2 cm/s
- Note:
  - For MeasMd = HiSpd, any max. change rate is possible
  - For MeasMd = HiAcc, max. is 10 cm/s

### 5.3 Automated adjustment of the Interference signal limit

The adjustment of the interference signal limit (TrsHld) can be carried out automatically in many applications.

#### Configuration

1. Set a fill level of 30%.
2. Log in to expert mode; see "5.1 Expert mode".
3. Perform in the EXPRT-Pulse-AutoTn menu.

The sensor calculates a suitable value for TrsHld.



**Note:**

This setting can be used only in pulse mode.

#### Blanking the interference signals in the masked zone

To blank interference signals from the range above the maximum expected fill level, a zone can be masked (dead zone). This zone begins at the process connection and continues up to the configured point. If signal values above the defined limit value (TrsHld) occur within this range, the sensor enters a safe state and signals the error ! MaskZ.

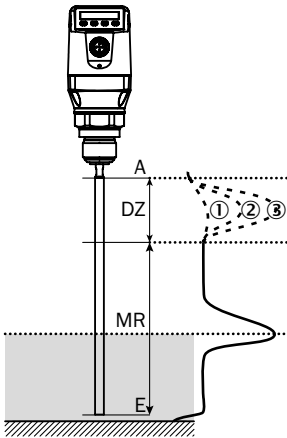

MaskTr	①		②		③	
	DZ	M	DZ	MR	DZ	MR
20%	x	R ✓	✓	x	✓	x
100%	x	✓	x	✓	✓	x
200%	x	✓	x	✓	x	✓

- ① No reflection/very weak reflection
- ② Weak reflection (e.g. spray water)
- ③ Strong reflection (e.g. thick layer of ketchup) DZ

**Dead zone**

- MR Active measuring range
- x No detection/measurement
- ✓ Detection/measurement

### Configuration

1. Log in to expert mode; see “5.1 Expert mode”.
2. Define the parameter in the EXPRT-Pulse-MaskZn menu.

**Note:**

This setting can be used only in pulse mode.

---

### 5.4 Selection of evaluation method

You can switch between pulse mode and foam mode as an evaluation method. Depending on the selected mode, other evaluation algorithms are used.

### Configuration

1. Log in to expert mode; see “5.1 Expert mode”.
2. In the EXPRT-Config-Mode menu, select between Pulse and Foam.

The following rules apply:

- Mode = Pulse: The sensor measures either with or without AutCal.
- Mode = Foam: The sensor measures only with valid CalEmp+CalMed. If no valid calibration is available, the CalPIs message is displayed and the sensor enters a safe state.

**Note:**

If AutCal is called up while the sensor is in foam mode, then AutCal is denied and the error message !Denid is shown.

---

### 5.5 Testing the configuration

#### Testing outputs

Switching/analog outputs can be simulated. This makes it possible to check the wiring and signal values on the connected systems, such as the PLC control, relay and lamps.

#### Configuration

**Activate the Qx switching output**

- ▶ Set the parameter in the QxMENU-SimQx menu to QxOn.

Additional options:

- QxOff = switching output off
- QxNorm = switching output in measuring operation
- QxOn = switching output is active

**Note:**

The simulation is automatically deactivated if the supply voltage is interrupted.

- Activate the QA analog output
  - Set the parameter in the *QAMENU-SimCur* or *SimVol* menu to the desired signal value.
    - *SimCur* for current output
    - *SimVol* for voltage output
- Note: The simulation is automatically deactivated if the supply voltage is interrupted.

### Simulating the level

- Even if there is no liquid in the container yet, it is possible to select a filling level in the menu in order to test the sensor configuration. When simulating a level value, all outputs on the NGR are set according to the defined configuration. The function should not be selected until a configuration is complete.

### Configuration

- Set parameter to the desired filling level as a % in the *SimLev* menu
- Note:
  - The level simulation refers to the probe length or container level (probe length + offset) if an offset is configured (see Chapter 5.12 "Setting the offset")
  - The simulation is only active when there are no error messages. The simulation is automatically deactivated if the supply voltage is interrupted.
- Parameter selection
  - *SimOff*: Off
  - Fill level 0%
  - Fill level 25%
  - Fill level 50%
  - Fill level 75%
  - Fill level 100%

## 5.6 Configuring the probe length

- Log into expert mode (see Chapter 5.1 "Expert mode")
- Access the *EXPRT-CONFIG-Length* menu using the arrow and Set pushbuttons.
- Enter the probe length in the *Length* menu. Please note the defined probe length in Chapter 8.8 "Dimensional drawings"
- Note:
  - *HiSpd*: max. length = 2,005 mm, response time < 400 ms
  - *HiAcc*: max. length = 6,005 mm, response time < 2,800 ms

## 5.7 Teaching in static interference signals

- Static interference signals in the tank generated by tubes, beams, couplings, or a cleaning ball can be taught-in. The probe length provides the value for the teach-in depth.
- Log into expert mode (see Chapter 5.1 "Expert mode")
- Access the *EXPRT-Config-CalRng* menu using the arrow and Set pushbuttons.
- Set the value range between 95 and 6,005 mm

## 5 Advanced functions

- Note:
  - The value starts from the NGR process connection
  - The value should cover all interference signals
  - Maximum value = probe length – 100 mm
  - *AutCal* function must be run after this (see Chapter 2 "Commissioning the NGR")
  - The *CalRng* parameter should always correspond to the probe length for NGRs with remote amplifier

### 5.8 Evaluating signal quality

Parameters describe the quality of the measuring signal.

- Log into expert mode (see Chapter 5.1 "Expert mode")

#### **SigQa1**

- Characteristic for the robustness of the *EXPRT-Config-TrsHld* setting
- Not active in foam mode. The displayed value is only valid if the sensor displays the correct level value.
  - Value range: 0 to 100%
  - Good signal: > 40% (a high pulse reserve is provided with the current *TrsHld* setting.)
- Measures: Reduce *EXPRT-Config-TrsHld* to increase *SigQa1*.
- Note:
  - Changing *TrsHld* will have an impact on *SigQa2* and *SigQa3*.
  - If a satisfactory *SigQa1* value cannot be achieved by adjusting *TrsHld* in conjunction with the *SigQa* values, the installation condition must be checked. Using a coaxial tube improves signal detection, particularly in media with low DK values (e.g., oil).

#### **SigQa2**

- Characteristic for the robustness of echo pulse detection in relation to interference pulses
- Not active in foam mode. The displayed value is only valid if the sensor displays the correct level value.
  - Value range: 0 to 100%
  - Good signal: > 50%
- Measures: Run *AutCal*; check installation conditions; remove deposits from probe and process connection

#### **SigQa3**

- Characteristic for signal noise and electromagnetic interference
  - Value range: 0 to 100%
  - Good signal: > 75%
  - Poor signal: < 50%
- Not active in foam mode. The displayed value is only valid if the sensor displays the correct level value.
  - Value range: 0 to 100%
- Measures:
  - Increase *EXPRT-Config-TrsHld*
  - *EXPRT-Config-MeasMd* = *HiAcc*
  - Improve filtering
  - Switch on filter
  - Reduce *EXPRT-Config-MaxCol*

### 5.9 Changing the coaxial cable length (in preparation)

- Valid for versions with remote amplifier.
- This setting makes it possible to configure the coaxial cable length between the sensor head and process connection.

#### Configuration

- Predefined coaxial cable length (1,000 mm, 2,000 mm, or 3,300 mm)
- Log into expert mode (see Chapter “5.1 Expert mode”)
- Configure the coaxial cable length in the EXPRT-Config-CbILen menu (1,000 to 3,300 mm)

Note:

Only the following configurations are permitted:

Coaxial cable length [mm]	Max. probe length [mm]	
	Foam mode inactive	Foam mode active
1,000	4,000	2,000
2,000	3,000	1,500
3,300	1,000	500

### 5.10 Activating the display lock

- To prevent the sensor from being tampered with, password protection can be activated for the display.
- When the protection is active, the expert password (000537) must be entered before the menu can be accessed.
- The menu is only unlocked once the correct password is entered.

#### Configuration

- Log into expert mode (see Chapter “5.1 Expert mode”)
- The protection can be (de)activated via the EXPRT-Config-Lock menu.

Note:

- The user is logged out again after 5 minutes of inactivity.
- When the display is locked, only the configured measured value display (DspVal) can be seen

### 5.11 Selecting the display unit (millimeter/inch)

- This setting makes it possible to display and configure all length measurements in either millimeters or inches.

#### Configuration

- Log into expert mode (see Chapter “5.1 Expert mode”)
- Set the unit in the EXPRT-Config-Unit menu (mm/inch)

## 5 Advanced functions

### 5.12 Setting the offset

- This setting makes it possible to indicate the level value on the display in relation to the tank bottom instead of the end of the probe. The actual container level is then indicated on the display.

#### Configuration

- Log into expert mode (see Chapter “5.1 Expert mode”)
- Set the offset in the EXPRT-Config-Offset menu (0 to 3,000 mm)
- See the following diagram

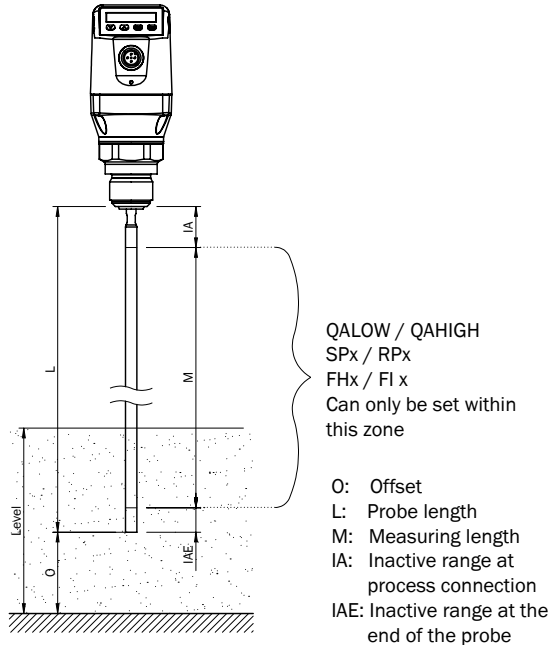

#### Note:

- If the offset parameter is changed, the SPx/RPx/FLx/FHx/QALOW/QAHIGH parameters are automatically adjusted.

### 5.12 Resetting the calibration

#### Resetting AutCal

1. Log in to expert mode; see “5.1 Expert mode”.
2. Reset AutCal in the EXPRT-Pulse-Reset menu.

#### Resetting CalEmp+CalMed

1. Log in to expert mode; see “5.1 Expert mode”.
2. Reset CalEmp+CalMed in the EXPRT-Foam-Reset menu.



## 6 Menu overview

Parameter	Description
<b>Q1MENU, Q2MENU, Q3MENU, Q4MENU</b>	See Chapter 3 "Configuring the switching outputs"
SPx	Switching point, switching output 1 or 2 or 3 or 4 (SPx > RPx) Note: Not displayed if the switching output in the OUX menu is set to error or window.
RPx	Reset switching point, switching output 1 or 2 or 3 or 4 Note: Not displayed if the switching output in the OU2/3/4 menu is set to error or window.
FHx FLx	<ul style="list-style-type: none"> <li>• Upper threshold (high) window function, switching output 2/3/4 (FHx &gt; FLx)</li> <li>• Lower threshold (low) window function, switching output 2/3/4</li> </ul> Note: Not displayed if the switching output in the OU2/3/4 menu is set to error or hysteresis.
Oux	Switching function, switching output <ul style="list-style-type: none"> <li>• Qx-Hno = Hysteresis function, normally open</li> <li>• Qx-Hnc = Hysteresis function, normally closed</li> <li>• Qx-Fno = Window function, normally open (function only available for Q2/3/4)</li> <li>• Qx-Fnc = Window function, normally closed (function only available for Q2/3/4)</li> <li>• Qx-Eno = Error signal, normally open (function only available for Q2/3/4)</li> <li>• Qx-Enc = Error signal, normally closed (function only available for Q2/3/4)</li> </ul> If Qx is used as an error signal, SPx/FHx and RPx/FLx are hidden in the menu.
SimQx	See Chapter 5.3 "Testing the configuration"
TYP2/3/4	<ul style="list-style-type: none"> <li>• Qx-PNP = Switching output in PNP circuit</li> <li>• Qx-NPN = Switching output in NPN circuit</li> <li>• Qx-Drv = Switching output executed in push/pull function</li> </ul>
<b>QAMENU</b>	See Chapter 4 "Configuring the analog output"
QAHIGH	Input of the fill level in mm for 20 mA/10 V signal (QAHIGH > QALOW)
QALOW	Input of the fill level in mm for 4 mA/0 V signal
QAPOL	The analog output signal can be inverted <ul style="list-style-type: none"> <li>• QA-Nrm = Analog output signal as configured</li> <li>• QA-INV = Analog output signal is inverted: QAHIGH 4 mA/0 V and QALOW 20 mA/10 V</li> </ul>
QATYP	Setting of the output signal <ul style="list-style-type: none"> <li>• 4-20 mA</li> <li>• 0-10 V</li> <li>• Auto V = Qa operated with voltage output of 0 to 10 V</li> <li>• Auto A = Qa operated with current output of 4 to 20 mA</li> <li>• Auto? = Automatic signal detection based on the existing load</li> </ul> During a menu query, either 4-20 mA or 0-10 V is displayed.

## 6 Menu overview

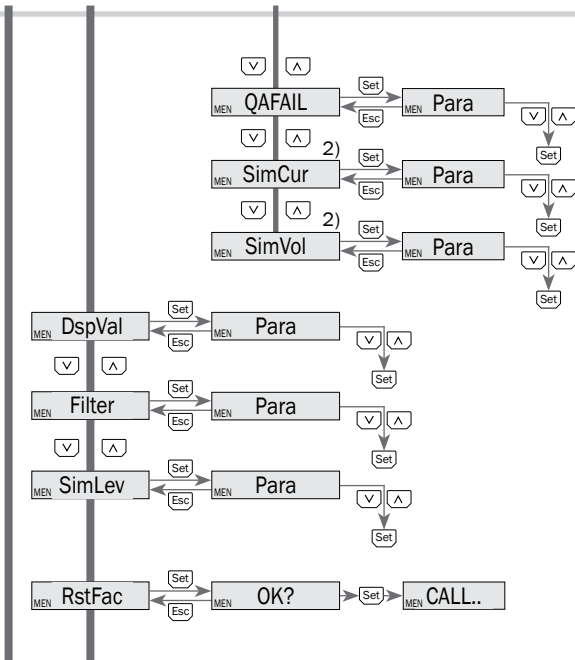

Menu overview continues on page 35.

2) Elements which are displayed depend on the QATYP parameter selection.

## 6 Menu overview

Parameter	Description
QAFAIL	Output behavior as per NE43 in the event of a fault (function only available when current output has been selected under QATYP). <ul style="list-style-type: none"> <li>• 3.5 mA = Analog current output is set to 3.5 mA in the event of a fault</li> <li>• 21.5 mA = Analog current output is set to 21.5 mA in the event of a fault</li> </ul>
SimCur	See Chapter 5.3 "Testing the configuration"
SimVol	See Chapter 5.3 "Testing the configuration"
<b>DspVal</b>	Display settings <ul style="list-style-type: none"> <li>• Distan = The display shows the distance in mm in relation to the end of the probe.</li> <li>• QaPerc = The display shows the fill level in % in relation to the QA analog output with the corresponding QAHIGH and QALOW thresholds.</li> <li>• QaBarG = The display shows a bar graph in relation to the QA analog output with the corresponding QAHIGH and QALOW thresholds.</li> <li>• QaSign = The display shows the current QA output value in mA or V.</li> <li>• QxSign = The display shows the output states.</li> </ul>
<b>Filter</b>	See Chapter 5.2 "Filtering measured values"
<b>SimLev</b>	See Chapter 5.3 "Testing the configuration"
<b>RstFac</b>	Resetting of the set parameters back to the factory settings

## 6 Menu overview

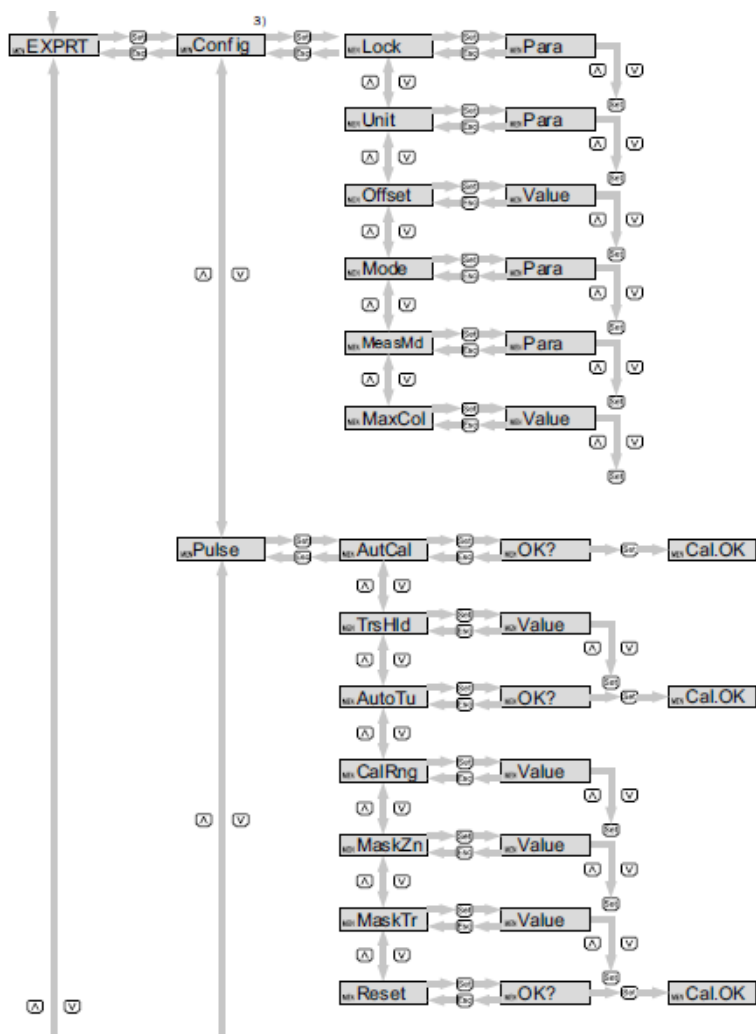

Menu overview continues on page 37.

▀ Password-protected measuring range.

## 6 Menu overview

Parameter	Description
<b>EXPRT</b>	See Chapter 5.1 "Expert mode"
Lock	See Chapter "5.10 Activating the display lock"
Unit	See Chapter "5.11 Selecting the display unit (millimeter/inch)"
Offset	See Chapter "5.12 Setting the offset"
MeasMd	<p>Measuring mode</p> <ul style="list-style-type: none"> <li>• HiSpd: max. length = 2,005 mm, response time &lt; 400 ms</li> <li>• HiAcc: max. length = 6,005 mm, response time &lt; 2,800 ms (more stable measured values, recommended for liquids with low DK values and where the TrsHld is &lt; 70)</li> <li>• mode-1: not supported, deactivates current AutCal/foam calibration</li> </ul>
Mode	See "5.4 Selection of evaluation method".
MaxCol	See Chapter "5.2 Filtering measured values"
<b>Pulse</b>	See "5.4 Selection of evaluation method".
AutCal	See "2 Commissioning the NGR".
TrsHld	<p>This value describes a factor which determines how strong an echo has to be in order to be recognized by the device. The value range lies between 20% and 500%. The default is 100% in this case. Only shown if password entered.</p> <ul style="list-style-type: none"> <li>• 20% = high sensitivity</li> <li>• 100% = standard</li> <li>• 500% = low sensitivity</li> </ul>
AutoTn	See "5.3 Automated adjustment of the interference signal limit".
CalRng	See "5.3 Automated adjustment of the interference signal limit".
MaskZn	See "5.3 Blanking the interference signals in the masked zone".
MaskTr	See "5.3 Blanking the interference signals in the masked zone".
Reset	Resets the values.

## 6 Menu overview

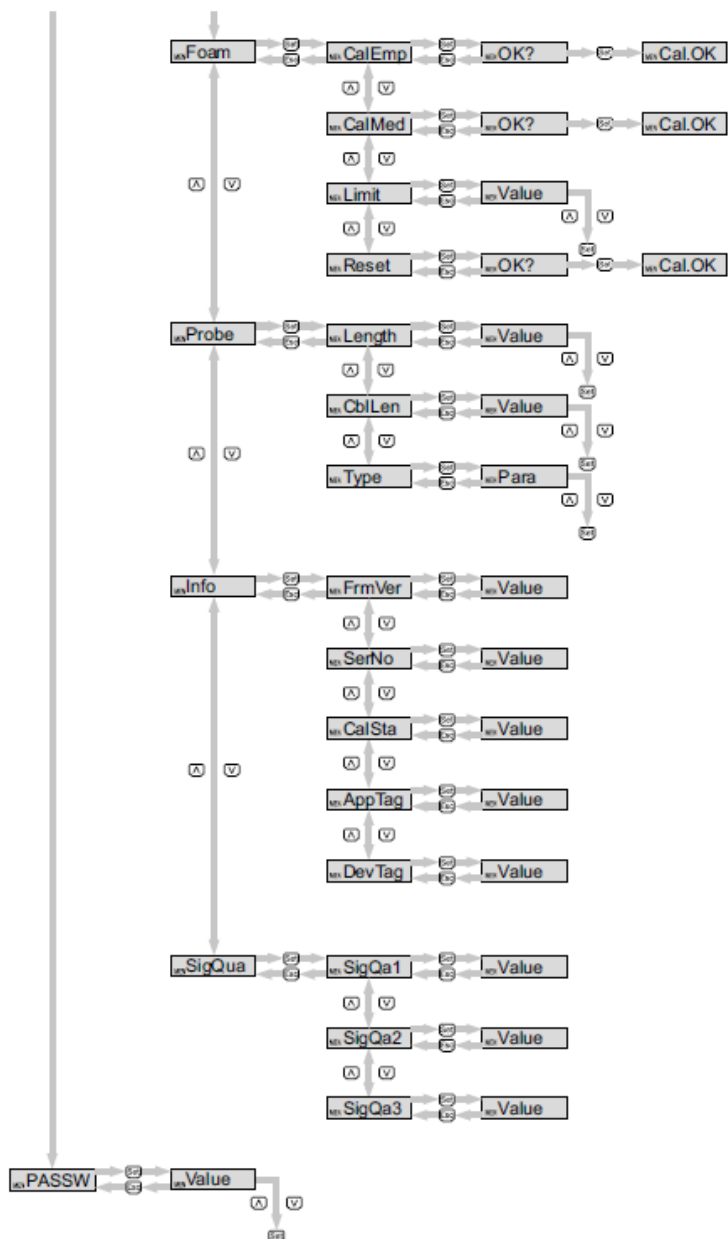

## 6 Menu overview

Parameter	Description
<b>Foam</b>	See “2.3 Foam commissioning (with factory settings)”.
CalEmp	See “2.3 Foam commissioning (with factory settings)”.
CalMed	See “2.3 Foam commissioning (with factory settings)”.
FomSta	Status of the foam calibration, read-only access <ul style="list-style-type: none"> <li>• inactive: CalEmp and/or CalMed not successful or not performed. Foam treatment inactive.</li> <li>• active: Foam treatment active</li> </ul>
Limit	Limit between foam and fluid. <ul style="list-style-type: none"> <li>• Range: 20 to 100%</li> <li>• Factory setting: 90%</li> <li>• Medium surface: 90%</li> <li>• Foam surface: &lt; 90%</li> </ul> <p>When measuring the foam surface, it may be necessary to reduce the limit. If the sensor displays a limit value that is too low, it is necessary to reduce the limit.</p>
<b>Probe</b>	Special settings.
Length	<ul style="list-style-type: none"> <li>• See “2.3 Foam commissioning (with factory settings)”</li> </ul>
CblLen	See “5.9 Changing the coaxial cable length”.
Type	Choosing between rod and rope.
<b>Info</b>	Sensor information
FrmVer	Shows the firmware version
SerNo	Shows the serial number
CalSta	Displays the status of the container calibration
AppTag	Measuring point name, can only be described via IO-Link.
DevTag	Device name, can only be written over IO-Link.
<b>SigQua</b>	Parameter describes the quality of the measuring signal.
SigQa1	See Chapter “5.8 Evaluating signal quality”
SigQa2	See Chapter “5.8 Evaluating signal quality”
SigQa3	See Chapter “5.8 Evaluating signal quality”
<b>StEcho</b>	This function makes it possible to save diagnostic data in the device.
<b>PASSW</b>	See Chapter “5.1 Expert mode”

## 7 Troubleshooting

### 7 Troubleshooting

#### 7.1 Error message on the display

Error	Cause	Solution
!InvEc & level present	AutCal not executed, interference superimposes medium reflection	Perform commissioning (see Chapter 2.1 "Quick commissioning")
	TrsHId setting is not suitable for the medium	Perform advanced commissioning (see Chapter 2.2 "Advanced commissioning")
!InvEc & empty tank	Probe length configured incorrectly	Check probe length and compare against configuration in EXPRT-Config-LENGTH
	Probe not available	Check probe
!ATTNT	A parameter was written outside of the valid value range and therefore adjusted	Write the value again inside of the valid range
	Another parameter was automatically adjusted due to a dependency (SPx, RPx)	Check parameter again
!WRONG	Incorrect password entered	Enter correct password
!NoCal	Information: The AutCal process or foam calibration was rejected because the probe length, teach-in depth, or measuring mode was changed	Perform commissioning again if necessary
!CalOk	The teach-in process was successful	
!NoSig	AutCal failed	Repeat commissioning
!faild	Foam-CalEmp or FoamCalMed menu item failed	Follow the foam commissioning instructions
!SC-Q1 !SC-Q2 !SC-Q3 !SC-Q4 !SC-Qa	Short-circuit at the output	Remove short-circuit
	Load resistance at the output is too low	Increase load resistance
!IOLOf	Supply voltage too low for IO-Link communication	Increase supply voltage to achieve the desired functionality
!QaOff	Supply voltage too low for analog output	Increase supply voltage to achieve the desired functionality
!QxOff	Supply voltage too low for switching outputs	Increase supply voltage to achieve the desired functionality
!QaOvf	The ohmic load at the analog current output Qa is too high	Reduce the load at Qa
	The analog current output Qa is not wired	Connect the load to Qa

## 7 Troubleshooting

Error	Cause	Solution
!Range	The maximum allowable measuring range was exceeded. Measurement in this configuration is not possible.	Reduce probe length and/or coaxial cable length (see Chapter "5.9 Changing the coaxial cable length")
!Cable	The coaxial cable is damaged/faulty	Replace the coaxial cable
	The coaxial cable length was configured incorrectly	See Chapter 5.9 "Changing the coaxial cable length"
Display only shows RUN. Otherwise the display is empty.	DspVal menu parameter is set to QaBarG and the level is below QALOW	Change QALOW or DspVal
Display off	Temperature too high	Reduce the temperature
	Temperature is too low	Increase the temperature
	No supply voltage	Connect sensor correctly
!Err[xx] !ErM[xx] !ErI[xx] !ErO[xx]	System error	The device is faulty and must be replaced. Replace the sensor.
NVFail	Memory error	The device is faulty and must be replaced. Replace the sensor.

### 7.2 Operating the display

Error	Cause	Solution
The menu item SPx/RPx is not displayed	QxMENU/OUx is not configured to Qx-Hno or Qx-Hnc	Perform configuration of Qx (see Chapter 3 "Configuring the switching outputs")
The menu item FHx/FLx is not displayed	QxMENU/OUx is not configured to Qx-Fno or Qx-Fnc	Perform configuration of Qx (see Chapter 3 "Configuring the switching outputs")
QAFail is not displayed	The analog output Qa is in voltage mode (QATYP = 0 to 10 V)	Perform configuration of Qa (see Chapter 4 "Configuring the analog output")
SimVol is not displayed	The analog output Qa is in current mode (QATYP = 4 to 20 mA)	Perform configuration of Qa (see Chapter 4 "Configuring the analog output")
SimCur is not displayed	The analog output Qa is in voltage mode (QATYP = 0 to 10 V)	Perform configuration of Qa (see Chapter 4 "Configuring the analog output")
EXPERT-Config... is not displayed	Correct password not entered	See Chapter 5.1 "Expert mode"

## 7 Troubleshooting

Error	Cause	Solution
EXPR-T-Foam-... is not displayed	Correct password not entered	See Chapter 5.1 "Expert mode"
Lengths are expressed as decimal numbers	Inch is activated as the display unit	Perform configuration of unit [see Chapter 5.11 "Selecting the display unit (millimeter/inch)"]
The menu only shows PASSW	Display lock is activated	See Chapter 5.10 "Activating the display lock"

### 7.3 Outputs

Error	Cause	Solution
Switching output does not behave as expected	Configuration incorrect	Perform configuration of the switching output (see Chapter 3 "Configuring the switching outputs")
	An error is pending; the sensor outputs are in a safe state	Remove the cause of the error
	Cable break	Check the cable
Analog output does not behave as expected	Configuration incorrect	Configure the analog output (see Chapter 4 "Configuring the analog output")
	An error is pending; the sensor outputs are in a safe state	Remove the cause of the error
	Cable break	Check the cable

### 7.4 Behavior

Error	Cause	Solution
Sensor shows high level after installation even though the tank is empty	AutCal not performed	Perform commissioning (see Chapter 2 "Commissioning the NGR")
When used with a coaxial tube, the sensor indicates a high level although the tank is empty	AutCal not performed	Perform commissioning (see Chapter 2 "Commissioning the NGR")
Level value fluctuates on the display	Medium surface unsettled	Activate filtering (see Chapter 2.1 "Quick commissioning")

## 7 Troubleshooting

Error	Cause	Solution
The displayed level value / SPx / RPx / FHx/FLx / QALOW/QAHIGH is greater than the probe length	An offset was configured for the level value	Adjust offset (See Chapter 5.12 "Setting the offset")
	Incorrect probe length configured	Adjust probe length (see Chapter 5.6 "Configuring the probe length")
Level occasionally jumps to a higher value	Contamination in the vicinity of the process connection	Clean
	Spray ball or feed dampen probe with medium above the medium surface	Observe the installation conditions Configure the MaxCoL plausibility filter (see chapter "5.2 Filtering measured values")
	Change in the ambient conditions regarding the situation during the AutCal process	Perform commissioning again (see Chapter 2 "Commissioning the NGR")
	Significant buildup of foam	Perform foam commissioning (see Chapter 2.3 "Foam commissioning")
	TrsHld set too low, the echo algorithm detects interference reflections	Increase TrsHld
Level occasionally jumps to 0 mm	TrsHld set too high	Perform advanced commissioning (see Chapter 2 "Commissioning the NGR")
	Significant buildup of foam	Perform foam commissioning
No measurement of low levels for media with low DKs	Increased inactive range at the probe end for media with a low DK	
Increased measurement inaccuracy	Use of foam algorithm	

### 8 Technical Data

#### 8.1 Features

<b>Medium</b>	Liquids				
<b>Detection type</b>	Limit, continuous				
<b>Probe length</b>	<table style="width: 100%; border: none;"> <tr> <td style="text-align: right; padding-right: 10px;"><b>Mono-rod probe</b></td> <td>200 mm to 2,000 mm</td> </tr> <tr> <td style="text-align: right; padding-right: 10px;"><b>Cable probe*</b></td> <td>1,000 mm to 4,000 mm</td> </tr> </table>	<b>Mono-rod probe</b>	200 mm to 2,000 mm	<b>Cable probe*</b>	1,000 mm to 4,000 mm
<b>Mono-rod probe</b>	200 mm to 2,000 mm				
<b>Cable probe*</b>	1,000 mm to 4,000 mm				
<b>Adjustable measuring range</b>	95 mm to 6,005 mm				
<b>Process pressure</b>	-1 bar to 10 bar				
<b>Process temperature</b>	-20 °C to +100 °C				
<b>RoHS certificate</b>	✓				
<b>IO-Link</b>	✓				

#### 8.2 Performance

<b>Accuracy <sup>1)</sup></b>	±5 mm
<b>Repeatability <sup>1)</sup></b>	≤ 2 mm
<b>Resolution</b>	< 2 mm
<b>Response time <sup>3)</sup></b>	< 400 ms

\* in preparation

## 8 Technical data

<b>Dielectric constant</b>	≥ 5 for mono-rod probe/cable probe* ≥ 1.8 with coaxial tube
<b>Conductivity</b>	No limitation
<b>Maximum change of level <sup>4)</sup></b>	500 mm/s
<b>Inactive area at process connection <sup>2)</sup></b>	25 mm
<b>Inactive area at end of probe <sup>1)</sup></b>	10 mm

<sup>1)</sup> With water under reference conditions.

<sup>2)</sup> With parameterized container with water under reference conditions, otherwise 40 mm.

<sup>3)</sup> Depends on measuring mode (high-speed < 400 ms, high accuracy < 2,800 ms)

<sup>4)</sup> Depends on configuration (MaxCol - maximum change of level)

### 8.3 Reference conditions

<b>Container with diameter</b>	1 m
<b>Minimum distance to built-in components</b>	> 300 mm
<b>Distance from end of probe to tank bottom</b>	> 15 mm
<b>Air humidity</b>	65% ± 20%
<b>Temperature</b>	+20 °C ± 5 °C
<b>Pressure</b>	1,013 mbar abs. ± 20 mbar
<b>Medium</b>	Water, DK = 80
<b>Centered installation of sensor</b>	✓
<b>Container parameterization carried out</b>	✓

## 8 Technical data

### 8.4 Measurement accuracy

Measurement accuracy with parameterized container

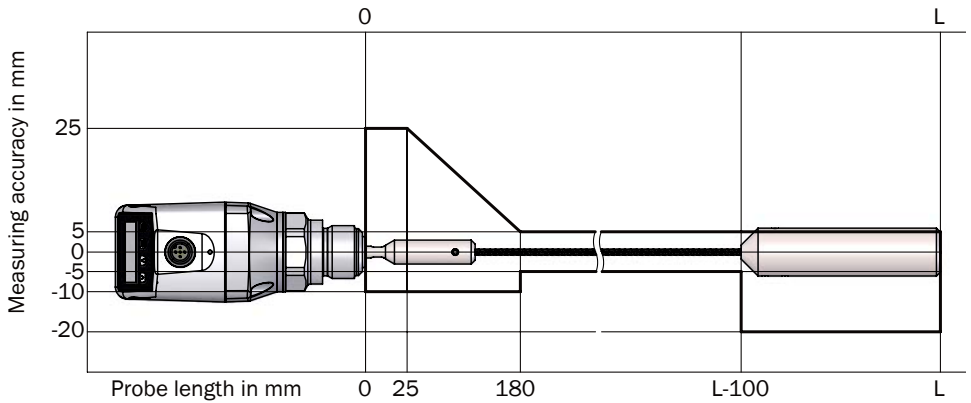
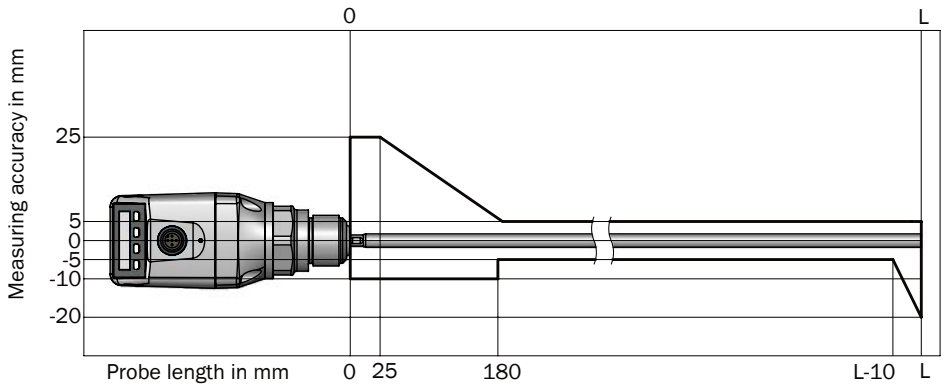

## 8 Technical data

### Measurement accuracy without parameterized container

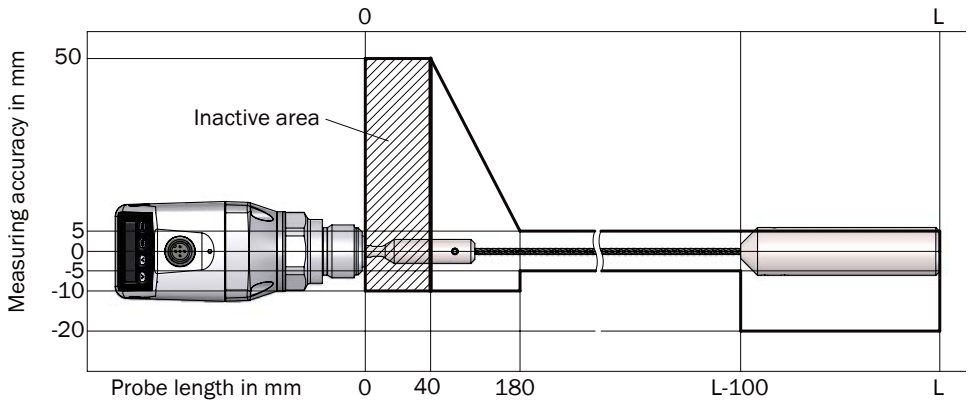
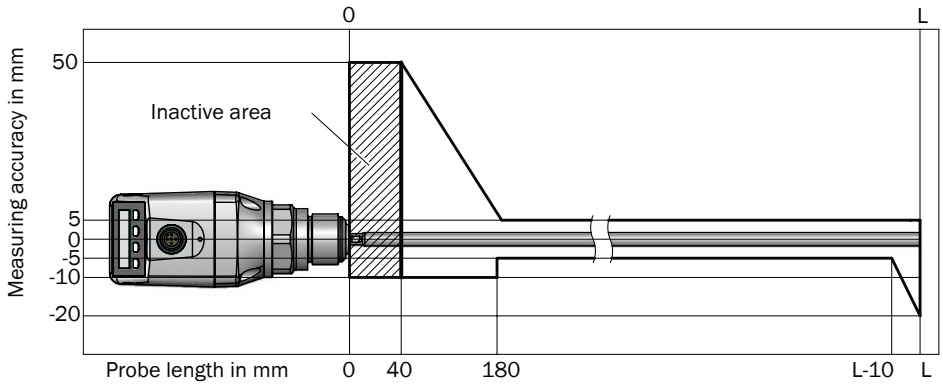

(in preparation)

## 8 Technical data

### 8.5 Mechanics/materials

<b>Wetted parts</b>	1.4404, PTFE
<b>Process connection</b>	G 3/4 A, 3/4" NPT
<b>Housing material</b>	Plastic PBT
<b>Max. probe load</b>	≤ 6 Nm
<b>Enclosure rating</b>	IP67: EN 60529
<b>Weight</b>	Max. 1.3 kg
<b>Coaxial cable insulation</b>	PVC

### 8.6 Electrical connection values

<b>Supply voltage</b> <sup>1)2)</sup>	12 V DC to 30 V DC
<b>Current consumption</b>	≤ 100 mA at 24 V without output load
<b>Initialization time</b>	≤ 5 s
<b>Protection class</b>	III
<b>Connection type</b>	M12 x 1 (5-pin) M12 x 1 (8-pin)
<b>Hysteresis</b>	Min. 3 mm, freely configurable
<b>Output signal</b> <sup>1)</sup>	4 mA to 20 mA / 0 V to 10 V automatically switchable depending on output load <sup>1)</sup> 1 PNP transistor output (Q1) and 1 PNP/NPN transistor output (Q2) switchable, or 1 PNP transistor output (Q1) and 3 PNP/NPN transistor outputs (Q2 to Q4) switchable (depending on type) <sup>1)</sup>
<b>Signal voltage HIGH</b>	U <sub>v</sub> -2 V
<b>Signal voltage LOW</b>	≤ 2 V
<b>Output current</b>	< 100 mA
<b>Inductive load</b>	< 1 H
<b>Capacitive load</b>	100 nF
<b>Temperature drift</b>	< 0.1 mm/K
<b>Output load</b>	4 mA to 20 mA < 500 ohms at U <sub>v</sub> > 15 V 4 mA to 20 mA < 350 ohms at U <sub>v</sub> > 12 V 0 V to 10 V > 750 ohms at U <sub>v</sub> ≥ 14 V
<b>Lower signal level</b>	3.8 mA to 4 mA
<b>Upper signal level</b>	20 mA to 20.5 mA
<b>EMC</b>	EN 61326-1:2006, 2004/108/EC

<sup>1)</sup> All connections are reverse polarity protected. All outputs are overload and short-circuit protected.

<sup>2)</sup> Use an energy-limited circuit for power supply as per UL61010-1 3rd Ed., Section 9.3

## 8 Technical data

### 8.7 Environmental conditions

<b>Ambient temperature, operation <sup>1)</sup></b>	-20 °C to +60 °C
<b>Ambient temperature, storage</b>	-40 °C to +80 °C

<sup>1)</sup> According to UL listing; degree of contamination 3 (UL61010-1: 2012-05); air humidity: 80% at temperatures up to 31 °C; installation height: max. 3,000 m above sea level; indoor applications only

8.8 Dimensional drawings

Dimensions in mm

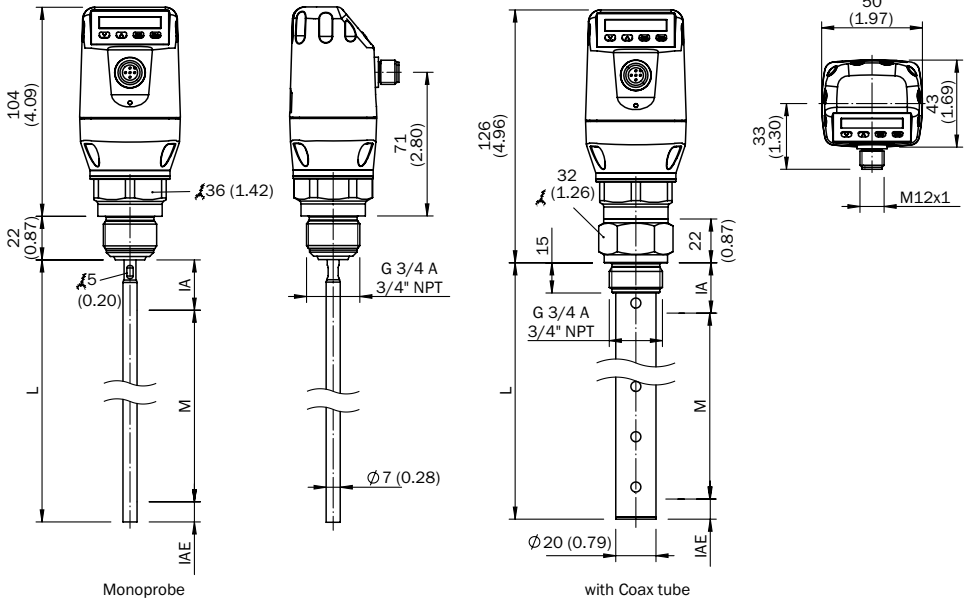

M: Measuring range

L: Probe length

IA: Inactive area at process connection 25 mm

IAE: Inactive area at probe end 10 mm

## 8 Technical data

### Standard version

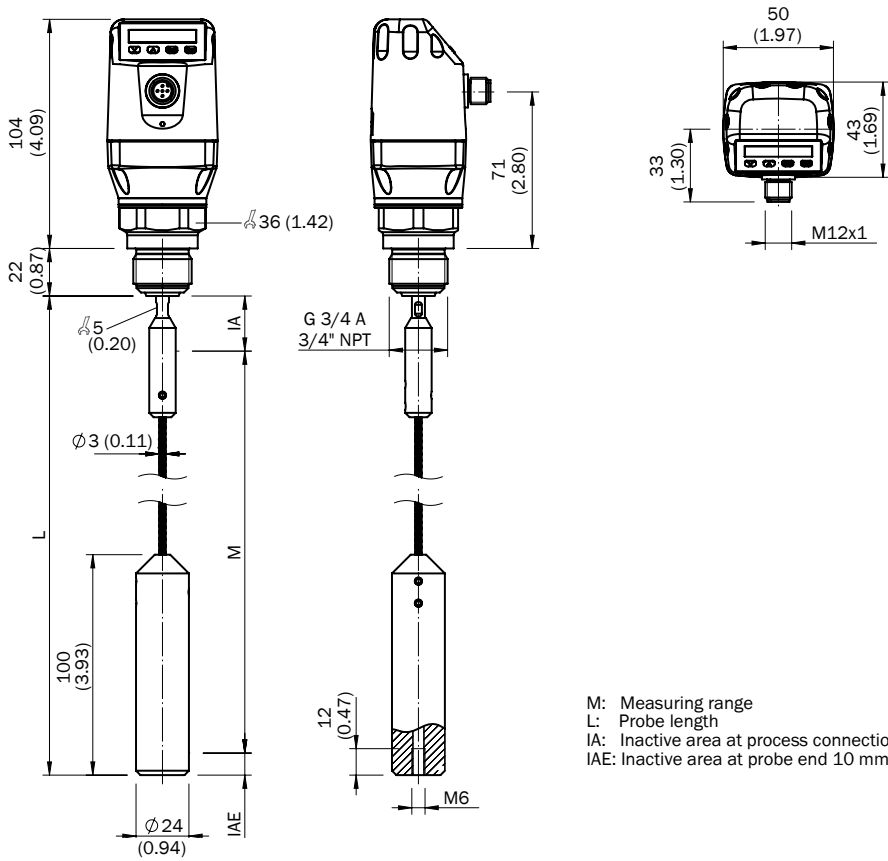

- M: Measuring range
- L: Probe length
- IA: Inactive area at process connection 25 mm
- IAE: Inactive area at probe end 10 mm

## 8 Technical data

### 8.9 Factory settings

Parameter	Factory setting
SP1	80% of the probe length measured from the end of the probe
RP1	5 mm below SP1
OU1	Q1_Hno
SP2	For 5-pin versions: 20% of the probe length measured from the end of the probe For 8-pin versions: 60% of the probe length measured from the end of the probe
RP2	5 mm below SP2
OU2	Q2_Hno
TYP2	Q2_PNP
SP3	40% of probe length measured from end of probe
RP3	5 mm below SP3
OU3	Q3_Hno
SP4	20% of the probe length measured from the end of the probe
RP4	5 mm below SP4
OU4	Q4_Hno
TYP3	Q3_PNP
TYP4	Q4_PNP
QAHIGH	50 mm below start of probe
QALOW	10 mm above end of probe
QAPOL	QA_Nrm
QATYP	Auto
QAFAIL	3.5 mA
SimCur	SimOff
SimVol	SimOff
DspVal	Distan
Filter	Off
SimLev	SimOff
TrsHld	100
MaskZn	0 mm
MaskTr	50%
Mode	Pulse
CalSta	noCal
Probe/Type	Depending on probe type: Rod/Rope
MaxCol	Depending on measuring mode: HiSped = AnySped, HiAcc = 10 cm/s
MeasMd	HiSpd
CalRng	6,005 mm
FomSta	Inactive
Limit	90
Offset	0 mm
Unit	mm
Lock	Inactive

## 9 Order Details

### 9 Order Details

#### Order Details (Example: NGR 1 2 4 2 G5 B)

Model	Version	Material	Signal Output	Contact	Connection	Probe length
NGR	1 = probe 2 <sup>2)</sup> = coaxial	2 = stainless steel/ PTFE	4 = 4-20 mA/ 0-10 V switchable	2 = 1xPNP+1xPNP/NPN 4 = 1xPNP+3xPNP/NPN	G5 = G $\frac{3}{4}$ male N5 = $\frac{3}{4}$ " NPT male	0 <sup>1)</sup> = probe length 2000 mm (standard) L/0000 = without probe (L = 0 mm) L/xxxx <sup>3)</sup> = probe length xxxx mm (4-digit number 0200...2000 mm rounded off to 10 mm) B <sup>1)</sup> = mounted on bypass
	4 = wire	2 = stainless steel	4 = 4-20 mA/ 0-10 V switchable	2 = 1xPNP+1xPNP/NPN	G5 = G $\frac{3}{4}$ male N5 = $\frac{3}{4}$ " NPT male	4 = probe length 4000 mm (standard) S = Length 1000...4000 mm (specify in clear text)

<sup>1)</sup> Only possible with NGR 1. Bypass-specification, see NBK-M data sheet

<sup>2)</sup> Using a coaxial tube improves signal detection, particularly in media with low DK values (e.g., oil)

<sup>3)</sup> L/2000 only possible for NGR 2. For NGR 1... and L = 2000 mm probe length code „0“ must be selected.

**Note:** Standard probe length «L» = 2000 mm (NGR 1242G50 on stock). Probe length «L» available in steps of 10 mm. Example: 200, 210, 220, 230...2000 mm.

Standard wire length «L» = 4000 mm (NGR 4242G50 on stock). Probe length «L» available in steps of 100 mm. Example: 1000, 1100, 1200, 1300...4000 mm. Please specify in clear text while ordering

#### Plug Connectors and Cables

Model	Brief description
ZUB-KAB-12K502	Cable, M12, 5-pin, straight connector female with molded cable, 2 m, PUR/PVC
ZUB-KAB-12K802	Cable, M12, 8-pin, straight connector female with molded cable, 2 m, PUR/PVC

## 10 Maintenance

The NGR is maintenance-free. We recommend doing the following regularly:

- Checking the probe for contamination

- Checking the screw connections and plug-in connections

## 11 Returning the level sensor

Declaration of no objection (contamination declaration in the event of service work)

Rinse off or clean removed devices before returning them in order to protect our employees and the environment from dangers posed by residue from measured materials. Faulty devices can only be examined when accompanied by a completed return form. A declaration of this type includes information about all materials which have come into contact with the device, including those which were used for testing purposes, operation, or cleaning. The return form is available at our Internet site ([www.kobold.com](http://www.kobold.com)).

### 12 Disposal

Dispose of device components and packaging materials in compliance with applicable country-specific waste treatment and disposal regulations of the region of use.

#### **Note!**

- Avoid environmental damage caused by media-contaminated parts
- Dispose of the device and packaging in an environmentally friendly manner
- Comply with applicable national and international disposal regulations and environmental regulations.

#### **Batteries**

Batteries containing pollutants are marked with a sign consisting of a crossed-out garbage can and the chemical symbol (Cd, Hg, Li or Pb) of the heavy metal that is decisive for the classification as containing pollutants:

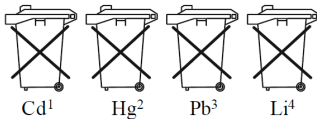

1. „Cd" stands for cadmium
2. „Hg" stands for mercury
3. „Pb" stands for lead
4. „Li" stands for lithium

#### **Electrical and electronic equipment**



### 13 Medium list

This medium list (from page 55) provides an overview of the DK values of liquids. Water-based liquids always have a DK value of > 5, which allows NGR to be used easily. For DK values of < 5, a coaxial tube or a metallic immersion tube/bypass is always required.

## Appendix 1 Medium list

Substance	DK value	Substance	DK value	Substance	DK value
Acetal (25°C)	3.8	Formic acid	57.9	Benzaldehyde	17.6
Acetaldehyde	15.0	Ammonia	15.0	Benzil (80°C)	10.0
Acetamide (77°C)	59.2	Ammonia solution (25%)	31.6	Benzine	2.0
Acetoacetic acid ethyl ester	15.0	Ammonia salt	4.3	Benzene	2.3
Acetone	21.5	Pentanol	14.8	Benzene, heavy	3.2
Acetophenone	18.0	Amyl amine	4.5	Benzyl alcohol	13.5
Acetylacetone	23.0	Aniline	7.0	Benzyl amine	4.6
Acetyl bromide	16.2	Anisealdehyde	22.3	Benzyl chloride	7.0
Acetyl chloride	15.9	Anisole	4.5	Beer brew	25.0
Acetylene dibromide	7.2	Anthracite	3.2	Bitumen	2.8
Acetylene tetrabromide	5.6	Antimony hydride	1.8	Hydrogen cyanide	158.0
Aconite acid ester	6.3	Malic acid diethylester	10.0	Bore oil emulsion	25.0
Adipic acid	1.8	Argon	1.5	Bornylacetate	4.6
Aerosile	1.0	Arsine	2.1	Bromine	3.1
Activated carbon	12.0	Arsole	2.3	Butanoic acid	3.0
Alum (60°C)	4.2	Asbestos	10.0	Camphene	2.3
Allyl alcohol	20.6	Ascorbic acid (vitamin C)	2.1	Caproic acid (71°C)	2.6
Allyl chloride	8.2	Azelaic acid diethylester	5.0	Caprylic acid	2.5
Allyl iodide	6.1	Azoxybenzene (36°C)	5.2	Carbazole	1.3
Aluminum bromide (100°C)	3.4	Basalt	2.5	Carbonylcyanide	10.7
Aluminum foil	10.8	Cotton fiber flour	3.2	Cellite	1.6
Aluminum hydroxide	2.5	Bauxite	2.5	Cetyl alcohol (60°C)	3.6
Aluminum splinters	7.3	Bentonite	8.1	Quinoline	8.8
Aluminum sulfate	2.6	Benzal chloride	6.9	Chlorine, liquid	2.1

## Appendix 1 Medium list

Substance	DK value	Substance	DK value	Substance	DK value
Chloral	6.7	Ice cream (-20°C)	16.5	Ferrozell	18.3
Chlorobenzine	5.7	Iron (III) oxide red	1.9	Fat coal	3.4
Chloroacetic acid	33.4	Emulphor	4.0	Fatty acid (35°C)	1.7
Chlorohydrin	31.0	Epichlorhydrin	23.0	Fish oil	2.6
Chlorinated lime	2.3	Peanuts, dried	3.1	Flax pellets	1.4
Chloroform (trichlormethane)	4.8	Peanut expeller	2.4	Meat and bone meal	1.9
Cola essence	17.3	Vinegar	24.0	Tankage	1.9
Cream (skin)	19.0	Acetic acid	6.2	Fly ash	3.3
Cuminaldehyde	10.7	Cement asbestos	3.2	Fluorine	1.5
Cyanogen	2.5	Ethanol (ethyl alcohol)	16.2	Fluorbenzene	6.4
Decalin	2.1	Ether	4.0	Hydrogen fluoride (0°C)	83.6
Degalan	3.1	Ethyl acetate	6.0	Calcium fluoride	2.5
Desmodur	10.0	Ethylamine	6.9	Formamide	109.0
Diacetone alcohol	18.2	Ethyl benzoate	6.0	Furan	3.0
Diamylether	3.0	Ethyl benzene	2.4	Furfurol	41.7
Dibenzofuran (100°C)	3.0	Ethylene chlorohydrin	25.0	Animal feed grist	2.4
Dibenzyl (60°C)	2.5	Ethylene chloride	10.6	Germanium tetrachloride	2.4
Diesel fuel	2.1	Ethylenediamine	15.0	Grain grist	3.0
Diethylamine	3.8	Ethylene oxide (-1°C)	13.9	Gypsum	1.8
Dimethylether (methyl ether)	5.0	Ethyl mercaptan	6.9	Fiber glass powder	1.1
Diofan	32.0	Fenchone	12.8	Glass granulate	4.0
Dioxane	2.0	Ferrite pellets	21.0	Cullet	2.0
Diphenyl (75°C)	2.5	Ferrosilicone	10.0	Glucose (50°C)	30.0
Printing ink	4.6	Green vitriol (80°C)	32.4	Glycerol	13.2

## Appendix 1 Medium list

Substance	DK value	Substance	DK value	Substance	DK value
Glycerol water	37.0	Splints	1.1	Isosafrol	3.3
Glycol	37.0	Honey	24.0	Iodine	11.1
Glysantin	25.0	Hydrazine	58.0	Iodobenzene	4.6
Granuform	4.0	Imidazole, pure (100°C)	23.0	Methyl iodide	7.1
Guaiacol	11.0	Isoamyl acetate	4.8	Hydrogen iodide	2.9
Guano (phosphate rock)	2.5	Isoamyl alcohol	15.6	Coffee beans	1.5
Oat	4.9	Isoamyl bromide	6.0	Cocoa beans	1.8
Urea	2.9	Isoamyl chloride	6.1	Caustic potash	3.3
Resin	1.5	Isoamyl ether	2.8	Potash salt	2.0
Hazelnuts	2.0	Isoamyl iodide	5.6	Lime	2.0
Hot glue (150°C)	2.3	Isobutanoic acid	2.6	Potato starch	1.7
Heating oil	2.1	Isobutyl alcohol	18.1	Ceramic compound	17.0
Helium	1.1	Isobutyl amine	4.4	Ketchup	24.0
Heptane	1.9	Isobutyl benzene	2.3	Gravel	2.6
Heptanal	9.1	Isobutyl bromide	7.2	Diatomaceous earth	1.4
Heptanoic acid (71°C)	2.6	Isobutyl chloride	6.5	Silicic acid	2.0
Heptene	2.1	Isobutyl cyanide	18.0	Bone fat	2.7
Hexane	1.9	Isobutyl iodide	6.5	Bonemeal	1.7
Hexene	2.1	Isobutyl nitrate	11.7	Sodium chloride	23.0
Hexanol	12.5	Isobutyl silane	2.5	Coal, 15% moisture	4.0
Hibiscus	2.8	Isoquinoline	10.7	Diethyl carbonate	2.8
Wood chips	2.3	Isocyanate	6.1	Coal dust	2.5
Charcoal	1.3	Isoprene	2.1	Coconut oil (refined)	2.9
Wood swarf	1.5	Isopropanol	18.0	Coke	3.0

## Appendix 1 Medium list

Substance	DK value	Substance	DK value	Substance	DK value
Cork powder	1.7	Flour	2.5	Nitroglycol	28.3
Concentrated feed	3.2	Molasses	31.3	Nitroglycerin	19.3
Chalk	2.1	Menthol (42°C)	4.0	Nitro varnish	5.2
Cresol	11.0	Mesityl oxide	15.0	Nitromethane	39.0
Cresol resin	18.3	Metal powder	6.0	Nitrophoska	5.4
Crystal sugar	2.0	Methanol (methyl alcohol)	33.0	Nitrosyl bromide (13°C)	15.2
Fertilizer	4.3	Methyl acetate	8.0	Nitrosyl chloride	19.0
Plastic pellets	1.2	Methylene bromide	7.0	Pasta, milled durum	1.9
Copper ore	5.6	Methylene chloride	9.0	Octane	2.0
Nitrous oxide	1.5	Methylene chloride	9.1	Octene	2.1
Lanolin	4.2	Methylene iodide	5.3	Octyl bromide	5.0
Latex	24.0	Methyl nitrate	23.5	Oil	2.0
Lauric acid ethyl ester	3.4	Methyl cellulose	3.0	Oleic acid	2.5
Glue	2.0	Monochloremethane	9.8	Water-in-oil emulsion	24.2
Linoleic acid	2.7	Morpholine	7.3	Oxalo ethyl acetate	6.0
Solvent	18.0	Naphthenic acid	2.6	Palmitic acid	2.3
Skim milk powder	2.3	Naphthalene	2.5	Palm tree nuts	2.2
Corn	3.6	Sodium carbonate	3.0	Palm tree nuts	2.8
Corn grist	2.1	Sodium methylate	1.5	Palm seed oil	1.8
Corn starch syrup	18.4	Sodium perborate	2.2	Paper scraps	1.2
Malt	2.7	Sodium peroxide	2.7	Paraffin	1.6
Mandelic acid nitril	18.0	Sodium sulfate	2.7	Paraldehyde	15.1
Marble stones small (2-	2.5	Nitrobenzene	35.0	Pelargon	2.8
Mice feed	2.3	Nitroethane	29.0	Penta borane	21.0

## Appendix 1 Medium list

Substance	DK value	Substance	DK value	Substance	DK value
Penta ethyl chloride	3.8	Liquid detergent	1.2	Nitric acid (98%)	19.0
Penta chlorotoluene	4.8	Propanal (15°C)	14.4	Hydrochloric acid	5.0
Pentane	1.8	Propanol (propyl alcohol )	2.2	Salt water	32.0
Pentanal (15°C)	11.8	Propanoic acid	3.2	Oxygen	1.5
Pentene	2.0	Propylamine	3.0	Chamotte	1.8
Perchlorate	3.6	Propylene, liquid	1.9	Foam flakes	1.1
Hexachlorobutadiene	2.6	Propylene chloride	9.0	Lard (80°C)	2.1
Perlite	1.7	Propylether	3.3	Soft soap	32.0
PET powder	1.5	PVC powder, pure	1.3	Chocolate powder	2.0
Phenetole	4.2	Pyridine	13.2	Black liquor	32.0
Phenol	8.0	Pyrrol	8.0	Sulfur	3.5
Phenol resin	7.4	Silica sand	2.0	Sulfur dioxide (sulfurous acid)	14.0
Phosgene	4.3	Quartz stone meal	2.7	Carbon disulfide, pure	2.6
Phosphate	4.0	Mercury diethyl	2.1	Sulfuric acid	21.9
Phosphorus, liquid	3.9	Rapeseed	3.3	Sulfuric acid (15%)	31.0
Phosphorus salt	4.0	Rapeseed grist	2.1	Sulfuric acid (97%)	8.6
Pinane	2.1	Rice	3.0	Sulfur trioxide	3.1
Piperidine	5.8	Rye	6.0	Hydrogen sulfide	6.0
Polyamide pellets	1.7	Rye bran	2.2	Heavy fuel oil	2.2
Polyethylene	1.2	Beetroot seeds	3.5	Soap flakes	9.2
Polypropylene	1.6	Beetroot cuttings	7.3	Soap pellets	3.5
Polyrol	2.8	Carbon black	18.8	Mustard	24.0
Polyvinyl acetals	2.8	Saccharose solution	20.0	Mustard seeds	3.6
Popcorn	1.1	Sawdust	1.3	Silicone oil	2.7

## Appendix 1 Medium list

Substance	DK value
Silicone rubber	2.9
Soy flour	4.5
Soy grains	2.9
Sunflower seeds	2.0
Chaff	1.5
Stearic acid	2.3
Rock salt (0–25 mm)	4.3
Styrene	2.4
Tobacco dust	1.8
Talcum	1.5
Tea powder	2.0
Tar, raw	4.0
Terephthalic acid	1.5
White spirit	2.0
Terpinene	2.7
Terpinolene	2.3
Tetrachloroethylene	2.5
Carbon tetrachloride	2.3
Thomaskali dust	3.4
Thujone (0°C)	10.8
Meat and bone meal	2.2
Titan tetrachloride	2.8
Toluene	2.4
Clay	2.3

Substance	DK value
Transformer oil	2.1
Trichloroethylene	3.2
Triethyl aluminum	2.9
Triptan	1.9
Dry yeast	2.0
Ultrasil	1.4
Undecan	2.0
Valeric acid	2.7
Viscose	34.5
Wax	1.8
Benzine	2.0
Water	80.3
Water (360°C)	10.0
Water, demineralized	29.3
Water, heavy	78.3
Sodium silicate	16.0
Hydrogen	1.2
Hydrogen peroxide, pure (0°C)	84.2
Wine	25.0
Tartaric acid	35.9
Wheat	4.0
Wheat starch	2.5
Xylitol	40.0
Xylene	2.3

Substance	DK value
Toothpaste	18.3
Cellulose	1.2
Cement	2.2
Zinc oxide	1.5
Zinc powder	4.4
Sugar	1.8
Tinder	12.0

## Appendix 2 Parameter table

### IO-Link Operating Instructions for NGR-XXXXXX

#### 1. Physical Layer

SIO Modus	yes
Min Cycle Time	18000 µs
Baudrate	COM2
Process Data Length	32 Bit

#### 2. Process Data

Record: 4 Byte															
Bitoffset															
Byte 0	Level	31	30	29	28	27	26	25	24						
Type/Access: Unsigned Integer 14															
Bitoffset															
Byte 1	Level	23	22	21	20	19	18	Reserved	17	16					
Type/Access: Unsigned Integer 14								7 Integer 12							
Bitoffset															
Byte 2	Reserved	15	14	13	12	11	10	9	8						
Type/Access: Integer 12															
Bitoffset															
Byte 3	Reserved	7	6	DeviceState	5	4	Q4	3	Q3	2	Q2	1	Q1	0	
Type/Access: Integer 12		6		Unsigned Integer 2		5		Boolean 4		Boolean 3		Boolean 2		Boolean 1	

#### 3. Service Data

IO-Link specific							
Index dec (hex)	Name	Format (Offset)	Length	Access <sup>1</sup>	Default Value	Value / Range	Remark [Unit]
16 (0x10)	Vendor Name	String	64 Byte	ro	Kobold Messring		
18 (0x12)	Product Name	String	64 Byte	ro	NGR-		
19 (0x13)	Product ID	String	64 Byte	ro	NGR-XXXXXX		
21 (0x15)	Serial Number	String	16 Byte	ro			
22 (0x16)	Hardware Version	String	64 Byte	ro			
23 (0x17)	Firmware Version	String	64 Byte	ro			
24 (0x18)	Application Specific Tag	String	Byte	rw	***		
Kobold device specific							
Index dec (hex)	Name	Format (Offset)	Length	Access <sup>1</sup>	Default Value	Value / Range	Remark [Unit]
64 (0x40)	Device Specific Tag	String	16 Byte	rw	***		
90 (0x5A)	Part Number	String	8 Byte	ro	Part Number		
100 (0x64)	SP1/FH1	UInt	16 Bit	rw	0..6005	Q1 SP1: Setpoint / FH1: High Limit Point	
101 (0x65)	RP1/FL1	UInt	16 Bit	rw	0..6005	Q1 RP1: Resetpoint / FL1: Low Limit Point	
102 (0x66)	OU1	UInt	8 Bit	rw	0 = Q1_Hno 1 = Q1_Hnc 2 = Q1_Fno 3 = Q1_Fnc 4 = Q1_Eno 5 = Q1_Enc	Q1 Function	
103 (0x67)	SimQ1	UInt	8 Bit	rw	0 = Q1Norm 1 = Q1On 2 = Q1Off	Simulate Q1	
104 (0x68)	SP2/FH2	UInt	16 Bit	rw	0..6005	Q2 SP2: Setpoint / FH2: High Limit Point	
105 (0x69)	RP2/FL2	UInt	16 Bit	rw	0..6005	Q2 RP2: Resetpoint / FL2: Low Limit Point	
106 (0x6A)	OU2	UInt	8 Bit	rw	0 = Q2_Hno 1 = Q2_Hnc 2 = Q2_Fno 3 = Q2_Fnc 4 = Q2_Eno 5 = Q2_Enc	Q2 Function	

ro = read only, wo = write only, rw = read/write

## Appendix 2 Parameter table

Kobold device specific							
Index dec (hex)	Name	Format (Offset)	Length	Access	Default Value	Value / Range	Remark [Unit]
107 (0x6B)	TYP2	UInt	8 Bit	rw	0 = Q2_PNP 1 = Q2_NPN 2 = Q2_DRV	Q2 Output Driver	
108 (0x6C)	SimQ2	UInt	8 Bit	rw	0 = Q2Norm 1 = Q2On 2 = Q2Off	Simulate Q2	
109 (0x6D)	SP3/FH3	UInt	16 Bit	rw	0...6005	Q3 SP3: Setpoint / FH3: High Limit Point	
110 (0x6E)	RP3/FL3	UInt	16 Bit	rw	0...6005	Q3 RP3: Resetpoint / FL3: Low Limit Point	
111 (0x6F)	OU3	UInt	8 Bit	rw	0 = Q3_Hno 1 = Q3_Hnc 2 = Q3_Fno 3 = Q3_Fnc 4 = Q3_Eno 5 = Q3_Enc	Q3 Function	
112 (0x70)	TYP3	UInt	8 Bit	rw	0 = Q3_PNP 1 = Q3_NPN 2 = Q3_DRV	Q3 Output Driver	
113 (0x71)	SimQ3	UInt	8 Bit	rw	0 = Q3Norm 1 = Q3On 2 = Q3Off	Simulate Q3	
114 (0x72)	SP4/FH4	UInt	16 Bit	rw	0...6005	Q4 SP4: Setpoint / FH4: High Limit Point	
115 (0x73)	RP4/FL4	UInt	16 Bit	rw	0...6005	Q4 RP4: Resetpoint / FL4: Low Limit Point	
116 (0x74)	OU4	UInt	8 Bit	rw	0 = Q4_Hno 1 = Q4_Hnc 2 = Q4_Fno 3 = Q4_Fnc 4 = Q4_Eno 5 = Q4_Enc	Q4 Function	
117 (0x75)	TYP4	UInt	8 Bit	rw	0 = Q4_PNP 1 = Q4_NPN 2 = Q4_DRV	Q4 Output Driver	
118 (0x76)	SimQ4	UInt	8 Bit	rw	0 = Q4Norm 1 = Q4On 2 = Q4Off	Simulate Q4	
119 (0x77)	QAHIGH	UInt	16 Bit	rw	0...6005	QA High Limit Point	
120 (0x78)	QALOW	UInt	16 Bit	rw	0...6005	QA Low Limit Point	
121 (0x79)	QAPOL	UInt	8 Bit	rw	0 = QA_Nrm 1 = QA_Inv	QA Polarity	
122 (0x7A)	QATYPE	UInt	8 Bit	rw	0 = 4-20mA 1 = 0-10V 2 = Auto 3 = Auto 4-20mA 4 = Auto 0-10V	QA Output Driver	
123 (0x7B)	QAFail	UInt	8 Bit	rw	0 = 3.5mA 1 = 21.5mA	QA Failure State	
124 (0x7C)	SimCur	UInt	8 Bit	rw	0 = SimOff 1 = 3.5mA 2 = 3.8mA 3 = 4.0mA 4 = 10.0mA 5 = 12.0mA 6 = 18.0mA 7 = 20.0mA 8 = 20.5mA 9 = 21.5mA	Simulate QA Current	
125 (0x7D)	SimVol	UInt	8 Bit	rw	0 = SimOff 1 = 0.0V 2 = 2.0V 3 = 4.0V 4 = 6.0V 5 = 8.0V 6 = 10.0V 7 = 10.5V	Simulate QA Voltage	
126 (0x7E)	DspVal	UInt	8 Bit	rw	0 = Distan 1 = Qa-Perc 2 = QaBarG 3 = QaSign 4 = QxSign	Display Mode	

## Appendix 2 Parameter table

Kobold device specific							
Index dec (hex)	Name	Format (Offset)	Length	Access	Default Value	Value / Range	Remark [Unit]
					6 = 600ms 10 = 1000ms 14 = 1400ms 20 = 2s 50 = 5s 100 = 10s		
128 (0x80)	SimLev	UInt	8 Bit	rw	0 = SimOff 1 = 0 % 2 = 25 % 3 = 50 % 4 = 75 % 5 = 100 %	Simulate Level	
205 (0xCD)	Profile Version	String	4 Byte	ro			
300 (0x12C)	Lock	Bool	1 Bit	rw	false = inactive true = active	Menu Password Protection	
301 (0x12D)	Unit	UInt	8 Bit	rw	0 = mm 1 = inch	Display Level Unit	
302 (0x12E)	Offset	UInt	16 Bit	rw	0	0...3000	Level Offset
303 (0x12F)	Mode	UInt	8 Bit	rw	0 = Pulse 1 = Foam	Algorithm Mode	
304 (0x130)	MeasMd	UInt	8 Bit	rw	0 = mode1 1 = HiSpd 2 = HiAcc 3 = mode2	Measuring Mode	
305 (0x131)	MaxCoL	UInt	8 Bit	rw	2 = 2cm/s 5 = 5cm/s 10 = 10cm/s 50 = AnySpeed	Maximum Change of Level	
310 (0x136)	TrsHld	UInt	16 Bit	rw	100	20...500	Threshold for Pulse Detection
311 (0x137)	CalRng	UInt	16 Bit	rw	6005	95...6005	AutCal Range
312 (0x138)	MaskZn	UInt	16 Bit	rw	0	0...6005	Masked Zone Range
313 (0x139)	MaskTr	UInt	16 Bit	rw	50	10...500	Masking Threshold
320 (0x140)	Limit	UInt	8 Bit	rw	90	20...100	Foam Algorithm Detection Limit
330 (0x14A)	Length	UInt	16 Bit	rw	95...6005	Probe Length	
331 (0x14B)	CblLen	UInt	16 Bit	rw	200...350 0	Coaxial Cable Length	
332 (0x14C)	Type	UInt	8 Bit	rw	0 = Rod 1 = Rope	Probe Type	
342 (0x156)	CalSta	UInt	8 Bit	ro	0 = NoCal 1 = AutCal 2 = FomCal 3 = CalMis	Calibration Status	
350 (0x15E)	SigQa1	UInt	8 Bit	ro		Signal Quality 1	
351 (0x15F)	SigQa2	UInt	8 Bit	ro		Signal Quality 2	
352 (0x160)	SigQa3	UInt	8 Bit	ro		Signal Quality 3	
360 (0x168)	SupplyVoltage	UInt	16 Bit	ro		Sensor Supply Voltage [V]	
361 (0x169)	SensorTemperature	Int	16 Bit	ro		Internal Electronics Temperature [°C]	
362 (0x16A)	PowerUpCounter	UInt	32 Bit	ro		Power Up Counter	
363 (0x16B)	OperatingTime	UInt	32 Bit	ro		Run Time [s]	
564 (0x16C)	SystemMonitor	Record	4 Byte	ro		System Monitor	
1 (0x01)	SystemState	Bit (0)	2 Bit	ro	0 = FAILURE 1 = WARNING 2 = OK		
2 (0x02)	SC-Q2	Bit (2)	1 Bit	ro	true = active false = -		
3 (0x03)	SC-Q3	Bit (3)	1 Bit	ro	true = Active false = -		
4 (0x04)	SC-Q4	Bit (4)	1 Bit	ro	true = Active false = -		
5 (0x05)	SC-Qa	Bit (5)	1 Bit	ro	true = Active false = -		
6 (0x06)	QaOvf	Bit (6)	1 Bit	ro	true = Active false = -		
7 (0x07)	reserved	Bit (7)	1 Bit	ro	true = Active false = -		
8 (0x08)	reserved	Bit (8)	1 Bit	ro	true = Active		

## Appendix 2 Parameter table

Kobold device specific							
Index dec (hex)	Name	Format (Offset)	Length	Access	Default Value	Value / Range	Remark [Unit]
9 (0x09)	InvEc	Bit (9)	1 Bit	ro	true = Active false = -		
10 (0x0A)	Cable	Bit (10)	1 Bit	ro	true = Active false = -		
11 (0x0B)	Range	Bit (11)	1 Bit	ro	true = Active false = -		
12 (0x0C)	MaskZ	Bit (12)	1 Bit	ro	true = Active false = -		
13 (0x0D)	Temp	Bit (13)	1 Bit	ro	true = Active false = -		
14 (0x0E)	reserved	Bit (14)	1 Bit	ro	true = Active false = -		
15 (0x0F)	reserved	Bit (15)	1 Bit	ro	true = Active false = -		
16 (0x10)	reserved	Bit (16)	1 Bit	ro	true = Active false = -		
17 (0x11)	reserved	Bit (17)	1 Bit	ro	true = Active false = -		
18 (0x12)	reserved	Bit (18)	1 Bit	ro	true = Active false = -		
19 (0x13)	reserved	Bit (19)	1 Bit	ro	true = Active false = -		
20 (0x14)	reserved	Bit (20)	1 Bit	ro	true = Active false = -		
365 (0x16D)	MinimumLevel	UInt	16 Bit	ro	0...6005	Minimum Level Since Power Up / Last Reset	
366 (0x16E)	MaximumLevel	UInt	16 Bit	ro	0...6005	Maximum Level Since Power Up / Last Reset	
380 (0x17C)	InputData	Array	32 Byte	rw	Unsigned Integer8 [32]	Input Data	
381 (0x17D)	OutputData	Array	32 Byte	ro	Unsigned Integer8 [32]	Output Data	
382 (0x17E)	UniqueID	Array	8 Byte	ro	Unsigned Integer8 [8]	Unique Device ID	
383 (0x17F)	Reserved	Array	8 Byte	rw	Unsigned Integer8 [8]	Reserved	

#### 4. Standard Command

Index dec (hex)		Access	Value	Name	Remark [Unit]
2 (0x02)	Standard Command	wo	130	Restore Factory Settings	
			165	Pulse_AutCal	
			166	Pulse_AutoTune	
			167	Pulse_Reset	
			170	Foam_CalEmp	
			171	Foam_CalMed	
			172	Foam_Reset	
			180	Reserved0	
			190	Reset_LevelMinMax	
			200	Reserved1	
			201	Reserved2	
			202	Reserved3	
			203	Reserved4	

## 14. IO Link Manufacturer's Declaration



### MANUFACTURER'S DECLARATION OF CONFORMITY

We:

**Kobold Messring GmbH**  
Nordring 22-24  
65719 Hofheim  
Germany

declare under our own responsibility that the product(s):

**NGR-XXXXXX** (IO-Link Device)

to which this declaration refers conform to:

- IO-Link Interface and System Specification, V1.1, July 2013 (NOTE 1,2)
- IO Device Description, V1.1, August 2011
- IO-Link Interface and System Specification, V1.0, January 2009 (NOTE 1)
- IO Device Description, V1.0.1, March 2010

The conformity tests are documented in the test report:

*IO-Link\_Device\_TestReport\_NGR\_Kobold\_2015.11.06.pdf*

*IO-Link\_PhysicalLayer\_TestReport\_NGR\_Kobold\_2015.11.12.pdf*

*IO-Link\_Integration\_TestReport\_NGR\_Kobold\_2015.05.06.pdf*

Issued at Hofheim, 22.05.2024

**Hans Volz**  
General Manager

**Joseph Burke**  
Compliance Manager

Reproduction and all distribution without written authorization prohibited

NOTE 1 Relevant Test specification is V1.1, July 2014

NOTE 2 Additional validity in Corrigendum Package 2015

## 15 EU Declaration of Conformance

### 15 EU Declaration of Conformance

We, KOBOLD Messring GmbH, Nordring 22-24, 65719 Hofheim, Germany, declare under our sole responsibility that the product:

**Level Sensor      Model: NGR-XXXXXX**

to which this declaration relates is in conformity with the following EU directives stated below:

**2014/30/EU      EMC Directive**  
**2011/65/EU      RoHS (category 9)**  
**2015/863/EU      Delegated Directive (RoHS III)**

Also, the following standards are fulfilled:

**EN 61326-1      Emissions: Class A**  
**EN 61326-2-x      Immunity: Industrial environment**  
**EN IEC 63000:2018      Technical documentation for the assessment of electrical and electronic products with respect to the restriction of hazardous substances**

Hofheim, 22 May 2024



H. Volz  
General Manager



Joseph Burke  
Compliance Manager

## 16 UK Declaration of Conformance

### 16 UK Declaration of Conformance

We, KOBOLD Messring GmbH, Nordring 22-24, 65719 Hofheim, Germany, declare under our sole responsibility that the product:

**Level Sensor                      Model: NGR-XXXXXX**

to which this declaration relates is in conformity with the following UK directives stated below:

**S.I. 2016/1091                      Electromagnetic Compatibility Regulations 2016**  
**S.I. 2012/3032                      The Restriction of the Use of Certain Hazardous  
Substances in Electrical and Electronic Equipment  
Regulations 2012**

Also, the following standards are fulfilled:

**EN 61326-1                              Emissions: Class A**  
**EN 61326-2-x                            Immunity: Industrial environment**  
**EN IEC 63000:2018                    Technical documentation for the assessment of  
electrical and electronic products with respect  
to the restriction of hazardous substances**

Hofheim, 22 May 2024



H. Volz General  
Manager



Joseph Burke  
Compliance Manager

**Sold by:**

Kobold Messring GmbH  
Nordring 22-24  
D-65719 Hofheim  
Tel.: +49(0)6192-299-0  
Fax: +49(0)6192-23398  
E-Mail: [info.de@kobold.com](mailto:info.de@kobold.com)  
Internet: [www.kobold.com](http://www.kobold.com)

**Version: K10/0524**