

Operating Instruction
for
Mini Bypass Level
Indicator

Model: NBK-M

1. Contents

1. Contents.....	2
2. Note	3
3. Instrument Inspection.....	3
4. Regulation Use	4
4.1. Bypass measuring tube system	4
5. Electrical Connection	4
6. Operating Principles.....	5
7. Mechanical Connection.....	6
8. Commissioning.....	7
9. Trouble Shooting.....	8
10. Maintenance	9
11. Technical Information.....	10
12. Order Codes	10
13. Dimensions	11
14. Options.....	14
15. Disposal	15
16. EU Declaration of Conformance	16

Manufactured and sold by:

Kobold Messring GmbH
Nordring 22-24
D-65719 Hofheim
Tel.: +49(0)6192-2990
Fax: +49(0)6192-23398
E-Mail: info.de@kobold.com
Internet: www.kobold.com

2. Note

Please read these operating instructions before unpacking and putting the unit into operation. Follow the instructions precisely as described herein.

The instruction manuals on our website www.kobold.com are always for currently manufactured version of our products. Due to technical changes, the instruction manuals available online may not always correspond to the product version you have purchased. If you need an instruction manual that corresponds to the purchased product version, you can request it from us free of charge by email (info.de@kobold.com) in PDF format, specifying the relevant invoice number and serial number. If you wish, the operating instructions can also be sent to you by post in paper form against an applicable postage fee.

The devices are only to be used, maintained and serviced by persons familiar with these operating instructions and in accordance with local regulations applying to Health & Safety and prevention of accidents.

When used in machines, the measuring unit should be used only when the machines fulfil the EC-machine guidelines.

Classification per PED 2014/68/EU

In acc. with Article 4, Paragraph 3, "Sound Engineering Practice", of the PED 2014/68/EU no CE mark.

3. Instrument Inspection

Instruments are inspected before shipping and sent out in perfect condition. Should damage to a device be visible, we recommend a thorough inspection of the delivery packaging. In case of damage, please inform your parcel service / forwarding agent immediately, since they are responsible for damages during transit.

Scope of delivery:

The standard delivery includes:

- Mini Bypass Level Indicator model: NBK-M

4. Regulation Use

Any use of the Mini-Bypass Level Indicator, model: NBK-M, which exceeds the manufacturer's specifications, may invalidate its warranty. Therefore, any resulting damage is not the responsibility of the manufacturer. The user assumes all risk for such usage.

The NBK-M Mini Bypass Level Indicator is used for continuous measurement, indication, and monitoring of liquids in tanks, vessels, reservoirs, basins etc. Information is displayed on a magnetically coupled roller indicator.

4.1. Bypass measuring tube system

The bypass tube is attached at the side of the vessel with a connecting flange or threaded pipe. The installation position is always vertical. The NBK should only be used for liquids with the medium density specified on the nameplate. Otherwise, the indication will deviate and the float may sink or float too high. Vessel inner pressure and medium temperature should not exceed the specified maximum values, as this can lead to the destruction and/or malfunction of the bypass system. It is imperative that the materials used are compatible with to the liquid being measured.

Proper operation is also impaired by:

- High degree of soiling
- Large suspended particles
- Crystallisation
- Ferrite particles

5. Electrical Connection

Optional electrical add-on parts (transmitter and limit contacts)

There are separate operating manuals for the assembly and commissioning of the optional electrical add-on parts: NMT/NBK-T, NBK-R and MM

These operating instructions document the following electrical add-on parts:

Transmitter:

Reed contact resistor chain model **W**

Reed contact resistor chain with transmitter model **M**

Magnetostrictive sensor with transmitter model **T**

Limit Contacts:

Reed switch limit contact model **NBK-RM**

Limit contact high temperature model **NBK-RT200M**

6. Operating Principles

The NBK-M works according to the principle of communicating tubes with a float, that is, the level in the bypass tube corresponds to the level in the vessel. A float with encased ring magnet in the bypass tube follows the liquid level, and transfers it, in a non-contacting manner, to a roller indicator that is externally attached. As the float passes by, the red/white rollers rotate through 180° about their own axis. Red indicates the actual level, whereas white means no level.

Contact devices and / or remote sensors can also be fitted. The arrangement is not important as the annular magnetic field acts in all directions.

7. Mechanical Connection

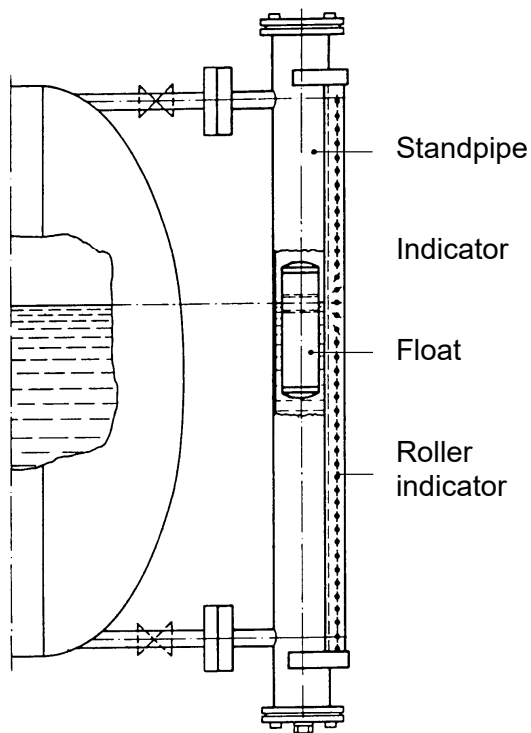

Remove bottom flange from bypass tube, and insert the cylindrical float in the NBK bypass tube with the designation "TOP" at the top. Re-position the gasket and close the bottom flange again; firmly tighten with screws. Mount and tighten the bypass tube to the vessel to be monitored with process connection and seal.

Normally it is sufficient to fix the complete NBK with both process connections. However, should the NBK be subjected to constant shock or strong vibrations it is recommended that the instrument is secured with rubber-damped tube clips.

The bypass tube should never be welded.

8. Commissioning

Because of the setting behaviour of seals, all screw connections must be retightened. Fill vessel, and switch on electrical controller, if existing. If there are stopcocks between bypass process connection and tank, first slowly open the upper valve (pressure relief) and then the lower valve (liquid side). If vent and drain valves have been installed, close them before filling.

The liquid that now enters the bypass tube raises the float until the level between tank and bypass tube is balanced. The roller indicator indicates the liquid level.

With the NBK-M for media density from 1.0 g/cm^3 , there is a guidewire in the lower process connection. This ensures the first filling or very low level to an optimized guidance of the float.

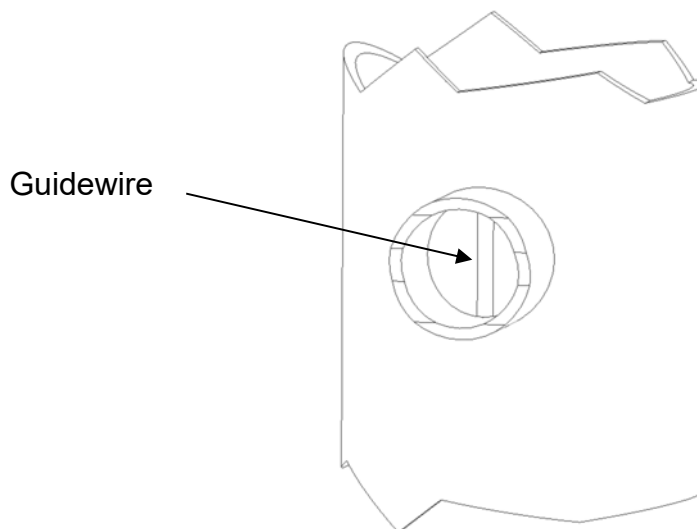

9. Trouble Shooting

Error: The tank is full but there is no indication

- Check that both flanges (process connection) top and bottom are open to the vessel, and that the bypass tube fills with liquid.
- Check that there is a float in the system.
- When the float is installed, check whether it is being blocked by foreign objects or dirt deposits.

Error: The tank is full but the indication is too low.

- Check that the density of the liquid is the same as the density given on the nameplate.
- Check that the float has been correctly installed with the marking "TOP" at the top.
- Check if dirt deposits in the bypass tube are blocking the float.

10. Maintenance

The drain plug should be opened occasionally, to wash out any deposits in case the liquid to be measured contains dirt particles, which could settle in the bypass tube. If encrustations or crystallisation have formed, the tank must be emptied or shut off; the lower cover flange must then be removed. The float should then be removed carefully from the vessel. The bypass tube can now be mechanically cleaned.

The inspection window for the roller indication is made of high-quality plexiglass (glass for high-temperature display). It should be cleaned with a suitable cleaning agent.

The indicator requires no further maintenance.

11. Technical Information

Process connection:	flange DIN EN 1092-1 type 11, form B ANSI-flange R-thread DIN EN 10226-1 NPT thread DN 10, DN 15, DN 20, DN 25
Bypass tube:	Ø 40 mm
Material:	1.4571
O-Ring (Ground flange):	NBR 70 (-20...+100 °C) (other materials as options)
Operating pressure:	PN 6/16/40 – 150 lbs / 300 lbs
Operating temperature:	-20 °C...+120 °C POM rollers -20 °C...+200 °C ceramic rollers
Protection roller indicator:	IP54
Viscosity:	max. 200 mm ² /s
Max. measuring length:	to 3000 mm one-piece
Total length:	according to measuring length, see dimension drawing
Float:	titanium, closed Special versions on request.

Pressure/temperature assignment for flanges made of austenite steel; 0.2% permanent elongation limit in accordance with DIN EN 1092-1:2001 (D).

Maximum permitted pressure

Type	-10...+50 °C	<100 °C	<150 °C	<200 °C
PN 6	5.6 bar	5.1 bar	4.7 bar	4.4 bar
PN 16	14.9 bar	13.5 bar	12.5 bar	11.7 bar
PN 40	37.3 bar	33.8 bar	31.3 bar	29.3 bar

12. Order Codes

Model	Nominal Pressure	Connection	Nominal Diameter	Roller Indicator	Measuring sensor	Medium density	Options
NBK-M	1= PN 6 (not with ASME flange) 2= PN 16 (150 lbs) 3= PN 40 (300 lbs)	F= DIN Flange A= ASME-Flange R= Tube thread N= NPT thread	10= DN 10 (only with DIN-flange) 15= DN 15, 1/2" 20= DN 20, 3/4" 25= DN 25, 1"	0= without P= POM rollers K= ceramic roller	0= without T= magnetostrictive W= chain of resistors M= chain of resistors with transmitter	8= from 0.8 g/cm ³ 1= from 1.0 g/cm ³	0= without ...= (see list)
NBK-RM	Standard Limit Contact						
NBK-RT200M	High-temperature contact max. 200 °C						

13. Dimensions

NBK-M with roller indication

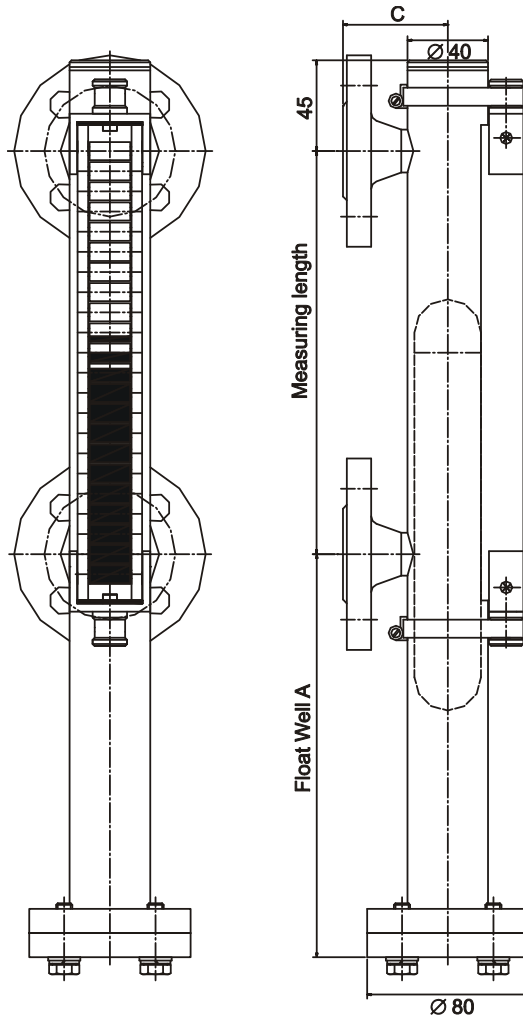

Dimension C [mm] for DIN V-flange

Model	DN 10	DN 15	DN 20	DN 25
PN 6	46	47	47	46
PN 16	53	55	55	75
PN 40	53	55	55	75

Dimension C [mm] for ANSI V-flange

Model	1/2"	3/4"	1"
150 lbs	64	67	66
300 lbs	69	72	73

Dimension C for R- or NPT thread: 60 mm

Dimension A: medium density 0.8 g/cm³: 290 mm
 medium density 1.0 g/cm³: 185 mm

NBK-M

NBK-M with roller indicator and magnetostrictive transmitter

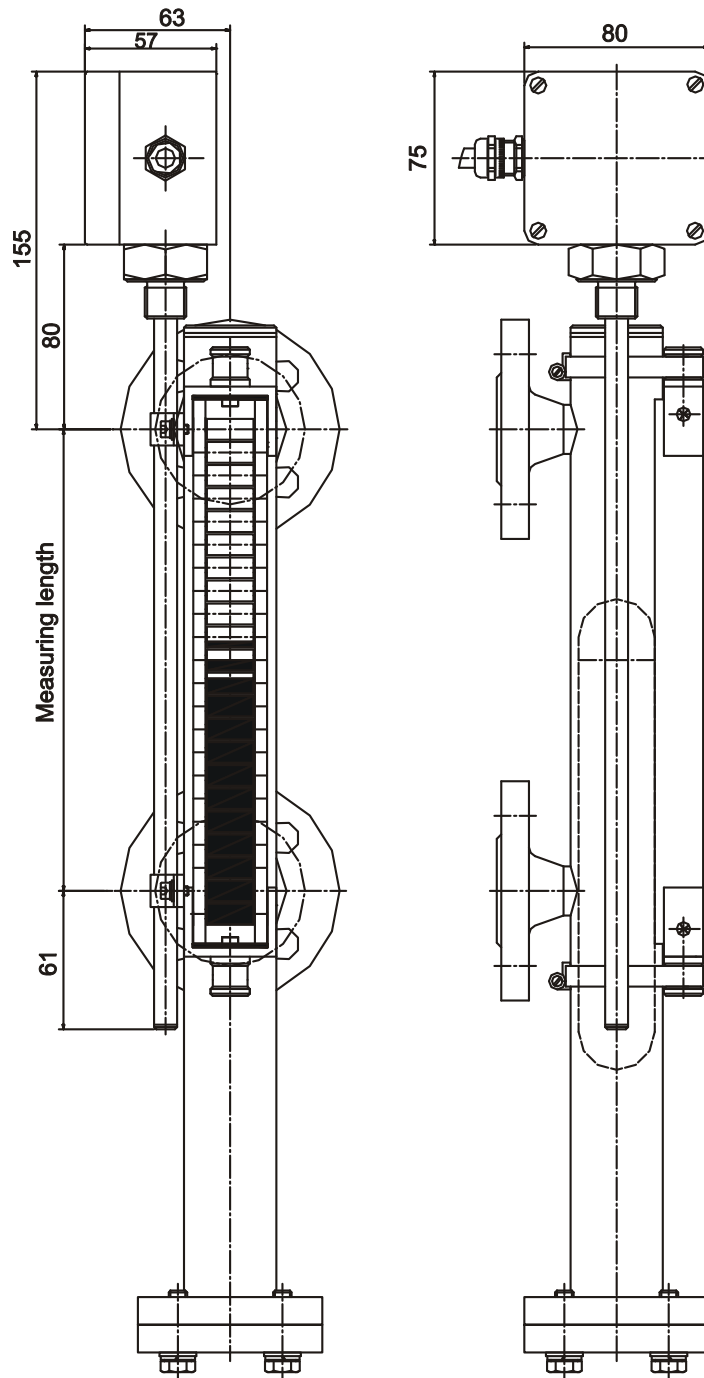

Drain flange E1

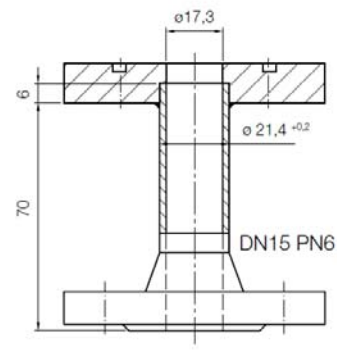
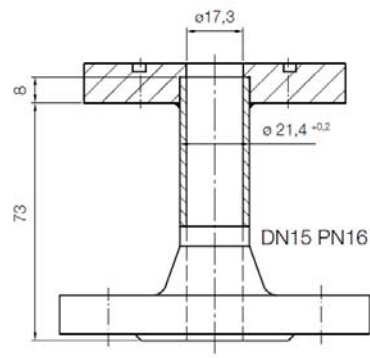
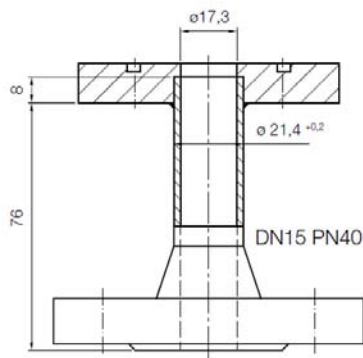

Drain flange E2

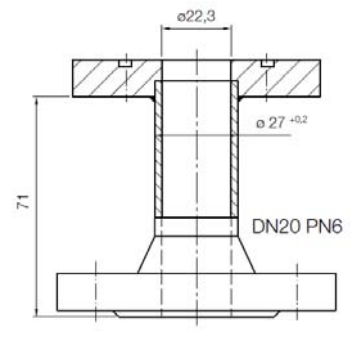
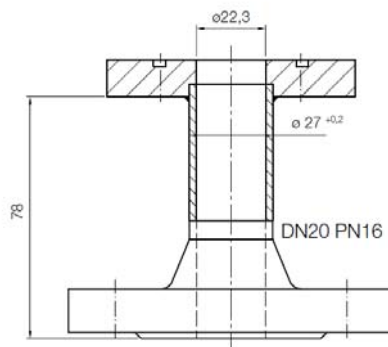
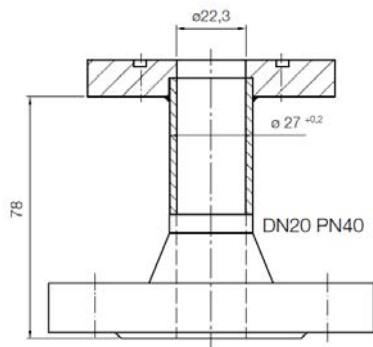

Option S1

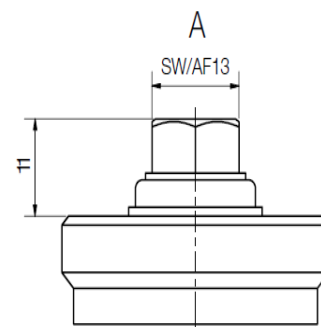
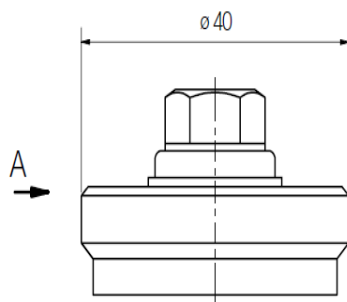

14. Options

- C¹⁾ Display appliance model ADI-1V30W2F0 with bar graph and digital display, sturdy aluminum housing, mounted on the bypass tube. For description see data sheet ADI-1
- E1²⁾ Drain flange DN 15, stainless steel 1.4571
- E2²⁾ Drain flange DN 20, stainless steel 1.4571
- E3 Drain flange ANSI ½", stainless steel 1.4571
- E4 Drain flange ANSI ¾", stainless steel 1.4571
- L1 Drain valve G ¼, stainless steel 1.4571
- L2 Drain valve ¼" NPT, stainless steel 1.4571
- H1 Rinsing connection DN 15/PN 16, top and bottom
- H2 Rinsing connection ANSI ½", 150 lbs, top and bottom
- M1 Measuring scale ambient temperature -20 °C ... +200 °C, aluminum backing, engraved scale
- M2 Measuring scale ambient temperature -20 °C...+150°C, aluminum, backing, polyester foil scale
- P Radiographic examination DIN 54111 T1
- Q Dye penetration test DIN 571-1
- X Pressure test with water 1.5 x PN
- Z 3.1 certificate as per EN 10204
- R1 Bottom drain screw, G ¼, seal PTFE
- R2 Bottom drain screw ¼" NPT, no seal
- S1²⁾ Vent plug G¼, seal PTFE
- S2 Vent plug ¼" NPT, no seal
- W1 O-ring (bottom flange) material: FPM (-15 °C ... +200 °C)
- W2 O-ring (bottom flange) material: PTFE (-20 °C ... +120 °C)
- W4 O-ring (bottom flange) material: perfluorelastomer (-20 °C ... +200 °C)

¹⁾ Use only with option T (magnetostrictive measuring sensor) or option M (resistor chain with measuring transducer)

²⁾ See drawing last page

Measuring scale, engraved, aluminum backing, option M1

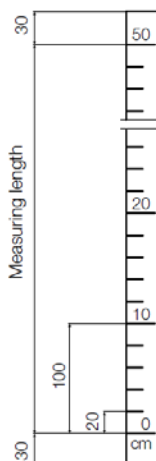

15. Disposal

Note!

- Avoid environmental damage caused by media-contaminated parts
- Dispose of the device and packaging in an environmentally friendly manner
- Comply with applicable national and international disposal regulations and environmental regulations.

Batteries

Batteries containing pollutants are marked with a sign consisting of a crossed-out garbage can and the chemical symbol (Cd, Hg, Li or Pb) of the heavy metal that is decisive for the classification as containing pollutants:

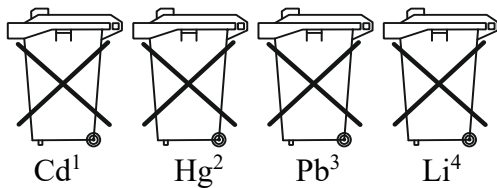

1. „Cd" stands for cadmium
2. „Hg" stands for mercury
3. „Pb" stands for lead
4. „Li" stands for lithium

Electrical and electronic equipment

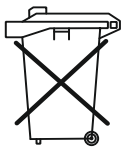

16. EU Declaration of Conformance

We, KOBOLD Messring GmbH, Nordring 22-24, 65719 Hofheim, Germany, declare under our sole responsibility that the product:

Mini Bypass Level Indicator

Model: NBK-M

to which this declaration relates is in conformity with the following EU directives stated below:

2011/65/EU

RoHS (category 9)

2015/863/EU

Delegated Directive (RoHS III)

Also, the following standards are fulfilled:

EN IEC 63000:2018 Technical documentation for the assessment of electrical and electronic products with respect to the restriction of hazardous substances

Hofheim, 22 May 2024



H. Volz
General Manager



J. Burke
Compliance Manager