

**Operating Instructions  
for  
Infrared Pyrometer**

**Model: TIN-SS**



We don't accept warranty and liability claims neither upon this publication nor in case of improper treatment of the described products.

The document may contain technical inaccuracies and typographical errors. The content will be revised on a regular basis. These changes will be implemented in later versions. The described products can be improved and changed at any time without prior notice.

© **Copyright**

**All rights reserved.**

## 1. Contents

---

1. Contents.....	2
2. Note .....	4
3. Instrument Inspection.....	4
4. Regulation Use .....	5
5. Operating Principle.....	6
5.1 Default settings .....	6
5.2 General specifications.....	8
5.3 Electrical specifications.....	8
5.4 Measurement specifications .....	10
5.5 Optical charts.....	11
5.6 Close focus optics.....	11
5.7 LED-Functions .....	12
6. Installation.....	14
6.1 Mechanical Installation .....	14
7. Electrical Installation .....	17
7.1 Digital communication.....	18
7.2 Open collector output.....	18
8. Schematic circuit diagrams for maintenance applications.....	19
9. Software for parameterization .....	20
9.1 Installation.....	20
9.2 Communication settings.....	21
10. Basics of Infrared Thermometry .....	21
11. Emissivity .....	22
11.1 Definition.....	22
11.2 Determination of unknown emissivity.....	22
11.3 Characteristic emissivity .....	23
12. Maintenance .....	23
13. Technical Information.....	24
14. Order Codes .....	24
15. Dimensions .....	24
16. Disposal .....	25
17. EU Declaration of Conformance .....	26
18. Appendix A – Table of emissivity for metals.....	27

19. Appendix B - Table of emissivity for non-metals .....	27
20. Appendix D – Smart Averaging.....	28

**Manufactured and sold by:**

Kobold Messring GmbH  
Nordring 22-24  
D-65719 Hofheim  
Tel.: +49(0)6192-2990  
Fax: +49(0)6192-23398  
E-Mail: [info.de@kobold.com](mailto:info.de@kobold.com)  
Internet: [www.kobold.com](http://www.kobold.com)

## 2. Note

---

Please read these operating instructions before unpacking and putting the unit into operation. Follow the instructions precisely as described herein.

The instruction manuals on our website [www.kobold.com](http://www.kobold.com) are always for currently manufactured version of our products. Due to technical changes, the instruction manuals available online may not always correspond to the product version you have purchased. If you need an instruction manual that corresponds to the purchased product version, you can request it from us free of charge by email ([info.de@kobold.com](mailto:info.de@kobold.com)) in PDF format, specifying the relevant invoice number and serial number. If you wish, the operating instructions can also be sent to you by post in paper form against an applicable postage fee.

Operating instructions, data sheet, approvals and further information via the QR code on the device or via [www.kobold.com](http://www.kobold.com)

The devices are only to be used, maintained and serviced by persons familiar with these operating instructions and in accordance with local regulations applying to Health & Safety and prevention of accidents.

When used in machines, the measuring unit should be used only when the machines fulfil the EC machinery directive.

## 3. Instrument Inspection

---

Instruments are inspected before shipping and sent out in perfect condition.

Should damage to a device be visible, we recommend a thorough inspection of the delivery packaging. In case of damage, please inform your parcel service / forwarding agent immediately, since they are responsible for damages during transit.

### **Scope of delivery:**

The standard delivery includes:

- Infrared Pyrometer                      model: TIN-SS

---

## 4. Regulation Use

---

Any use of the device, which exceeds the manufacturer's specification, may invalidate its warranty. Therefore, any resulting damage is not the responsibility of the manufacturer. The user assumes all risk for such usage.

The sensors of the TIN-SS series are non-contact infrared temperature sensors. They calculate the surface temperature based on the emitted infrared energy of objects (see chapter 10 Basics of Infrared Thermometry).



---

**The TIN-SS sensing head is a sensitive optical system. Please use only the thread for mechanical installation.**

---

- Avoid abrupt changes of the ambient temperature.
- Avoid mechanical violence on the head – this may destroy the system (expiry of warranty).
- If you have any problems or questions, please contact our service department.

## 5. Operating Principle

---

### 5.1 Default settings



**Smart Averaging means a dynamic average adaptation at high signal edges. [Activation via software only]. [see Appendix D – Smart Averaging]**



**The default settings can be changed with the optional USB adapter cable & software. If the unit is supplied together with the IR App Connector cable the output is already preset to digital communication (bidirectional).**

At time of delivery the unit has the following pre-settings:

Emissivity	0.950
Transmission	1.000
Average time	0.3 s
Smart averaging	active
Smart averaging hysteresis	2 °C
Ambient temperature source	internal (head)
Status-LED function	Self-diagnostic
Input (IN/ OUT/ green)	inactive
Output (OUT/ yellow)	mV output
Temperature range	0...350 °C
Output voltage	0...3.5 V
Thermocouple output	Inactive
Vcc adjust	inactive
Signal processing	Hold mode: off
Calibration	Gain 1.000/ Offset 0.0
Failsafe	Inactive

For a usage of the TIN-SS for online maintenance applications (in electrical cabinets e.g.) the following recommend settings are already included in the factory default setting (but not active):

<b>OUT</b>	<p>At <b>3-state output</b> the following settings are default:</p> <p>Pre-alarm difference: 2 °C          No alarm level: 8 V          Pre-alarm level: 5 V          Alarm level: 0 V          Service voltage: 10 V</p>																																	
<b>IN/ OUT</b>	<p>At <b>Alarm output (open collector)</b> the following settings are default:</p> <p>Mode: normally closed          Temp code output: activated (for values above alarm level)          Range settings: 0 °C = 0 %/ 100 °C = 100 %</p>																																	
<b>Vcc adjust</b>	<p>If <b>activated</b> the following settings are default:</p> <p>Output voltage range: 0-10 V          Difference mode: activated</p> <table border="1" data-bbox="616 994 1297 1364"> <thead> <tr> <th>Alarm level</th> <th>Alarm value (IN/ OUT pin)</th> <th>Vcc</th> </tr> </thead> <tbody> <tr><td>1</td><td>40 °C</td><td>11 V</td></tr> <tr><td>2</td><td>45 °C</td><td>12 V</td></tr> <tr><td>3</td><td>50 °C</td><td>13 V</td></tr> <tr><td>4</td><td>55 °C</td><td>14 V</td></tr> <tr><td>5</td><td>60 °C</td><td>15 V</td></tr> <tr><td>6</td><td>65 °C</td><td>16 V</td></tr> <tr><td>7</td><td>70 °C</td><td>17 V</td></tr> <tr><td>8</td><td>75 °C</td><td>18 V</td></tr> <tr><td>9</td><td>80 °C</td><td>19 V</td></tr> <tr><td>10</td><td>85 °C</td><td>20 V</td></tr> </tbody> </table>	Alarm level	Alarm value (IN/ OUT pin)	Vcc	1	40 °C	11 V	2	45 °C	12 V	3	50 °C	13 V	4	55 °C	14 V	5	60 °C	15 V	6	65 °C	16 V	7	70 °C	17 V	8	75 °C	18 V	9	80 °C	19 V	10	85 °C	20 V
Alarm level	Alarm value (IN/ OUT pin)	Vcc																																
1	40 °C	11 V																																
2	45 °C	12 V																																
3	50 °C	13 V																																
4	55 °C	14 V																																
5	60 °C	15 V																																
6	65 °C	16 V																																
7	70 °C	17 V																																
8	75 °C	18 V																																
9	80 °C	19 V																																
10	85 °C	20 V																																

## 5.2 General specifications

Environmental rating	IP63
Ambient temperature	-20...80 °C
Storage temperature	-40...85 °C
Relative humidity	10...95 %, non-condensing
Material	Stainless steel
Dimensions	85 mm, M12x1
Weight	58 g
Cable length	3 m
Cable diameter	4.3 mm
Vibration	IEC 60068-2-6 (sinus shape), IEC 60068-2-64 (broad band noise)
Shock	IEC 60068-2-27 (25G and 50G)

## 5.3 Electrical specifications

Used Pin		Function	
OUT	IN/ OUT		
x		Analog	0-5 V <sup>1)</sup> or 0-10 V <sup>2)</sup> / scalable
x		Alarm	output voltage adjustable; N/O or N/C
x		Alarm	3-state alarm output (three voltage level for no alarm, pre-alarm, alarm)
	x	Analog	programmable open collector output (NPN type) [0-30 V DC/ 50 mA] <sup>4)</sup>
	x	Temp. Code	Temp. Code Output (open collector (NPN type)) [0-30 V DC/ 50 mA] <sup>4)</sup>
	x	Input	programmable functions: <ul style="list-style-type: none"> <li>• external emissivity adjustment</li> <li>• ambient temperature compensation</li> <li>• triggered signal output and peak hold function <sup>5)</sup></li> </ul>
x	x	Serial digital <sup>3)</sup>	uni- (burst mode) or bidirectional
OUT t/c K		Analog	Thermocouple output type K; alternatively selectable to the mV output (software necessary)
Status LED		green LED with programmable functions: <ul style="list-style-type: none"> <li>• alarm indication (threshold independent from alarm outputs)</li> <li>• automatic aiming support</li> <li>• self-diagnostics</li> <li>• temperature code indication</li> </ul>	



Vcc adjust mode	10 adjustable emissivity and alarm values by variation of supply voltage/ Service mode for analog output
Output impedances	min. 10 kΩ load impedance
Current draw	10 mA
Power supply	5...30 VDC <sup>4)</sup>

<sup>1)</sup> 0...4.6 V at supply voltage 5 VDC; also valid for alarm output

<sup>2)</sup> only at supply voltage  $\geq 11$  V

<sup>3)</sup> inverted RS232, TTL, 9.6 kBaud

<sup>4)</sup> loadable up to 500 mA if the mV output is not used

<sup>5)</sup> High level:  $> 0.8$  V/ Low level:  $< 0.8$  V

<sup>6)</sup> The TIN-SS sensor may only be powered either via USB or externally, but not simultaneously!

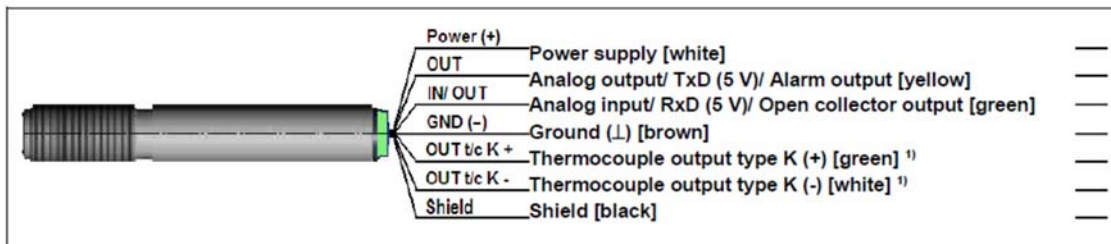

<sup>1)</sup> The t/c wires are indicated with an additional cable marker to avoid wrong connections due to the identical cable colors of other wires (white, green).

## 5.4 Measurement specifications

Temperature range	-50...1030 °C (scalable via Software)
Spectral range	8...14 µm
Optical resolution	15:1
CF-lens (optional)	0.8 mm@ 10 mm
Accuracy <sup>1) 2)</sup>	±1.5 °C or ±1.5 % of reading (whichever is greater)
Repeatability <sup>1)</sup>	±0.75 °C or ±0.75 % of reading (whichever is greater)
Temperature coefficient <sup>3)</sup>	±0.05 K/ K or ±0.05 %/ K (whichever is greater)
Temperature resolution (NETD) <sup>4)</sup>	50 mK
Response time	14 ms (90 % Signal/ adjustable to 999 s via Software)
Warm-up time	10 min
Emissivity/ Gain	0,100...1,100 (adjustable via 0-10 VDC input or software)
Transmissivity	0,100...1,000 (adjustable via software)
Interface (optional)	USB programming interface
Signal processing	Average, Peak hold, Valley hold, Advanced peak hold with threshold and hysteresis, Triggered signal output, Triggered peak hold function (adjustable via software)
Software / App	optional (Kobold Homepage)

<sup>1)</sup> at ambient temperature 23±5 °C and object temperatures >0 °C

<sup>2)</sup> Accuracy for thermocouple output: ±2.5°C or ±1%

<sup>3)</sup> for ambient temperatures <18 °C and >28 °C

<sup>4)</sup> at time constant of 200 ms and an object temperature of 200 °C

## 5.5 Optical charts



- The size of the measuring object and the optical resolution of the infrared thermometer determine the maximum distance between sensing head and measuring object.
- In order to prevent measuring errors the object should fill out the field of view of the optics completely. Consequently, the spot should at all times have at least the same size like the object or should be smaller than that.

The following optical charts show the diameter of the measuring spot in dependence on the distance between measuring object and sensing head. The spot size refers to **90 % of the radiation energy**. The distance is always measured from the front edge of the sensor housing/ CF-lens holder/ air purge.

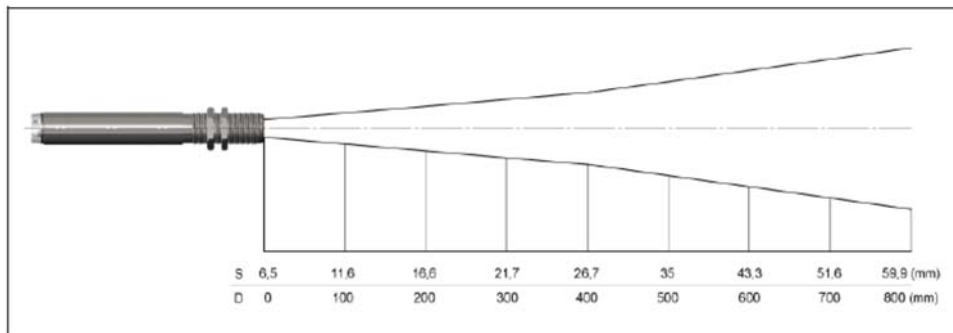

Optical chart TIN-SS (15:1)

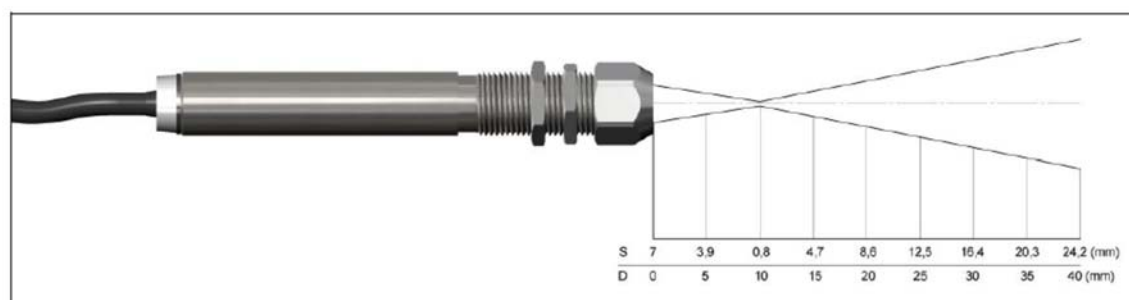

Optical chart TIN-SS (15:1) with CF-lens (0.8 mm@ 10 mm)

## 5.6 Close focus optics



- If the CF-lens is used, the transmission has to be set to 0.78. To change this value the optional USB-Kit (including software) is necessary.
- The assigned transmission (average value) is a characteristic value which may have a certain scattering. If required the transmission has to be determined.

The optional CF-lens allows the measurement of small objects. The CF optics can also be combined with a laminar air purge

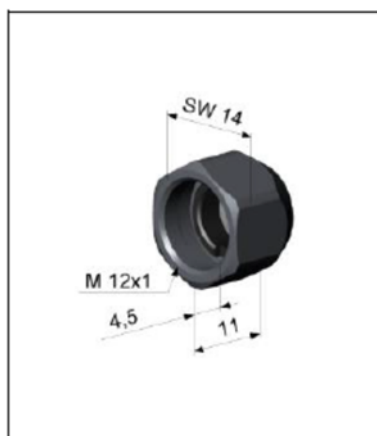

CF-lens [Order-No.: TIN-ZTCF]

## 5.7 LED-Functions

The green LED can be programmed for the following functions. For the programming the **USB adapter cable incl. software (option)** is necessary. The factory default setting for the LED is self-diagnostic.

LED Alarm	LED lights up if the object temperature exceeds or deceeds an alarm threshold
Automatic aiming support	Sighting feature for an accurate aiming of the CS to hot or cold objects
Self-diagnostic	LED is indicating different states of the sensor
Temperature Code indication	Indication of the object temperature via the LED
Off	LED deactivated

### 5.7.1 Automatic aiming support

The automatic aiming support helps to adjust the unit to an object which has a temperature different to the background. If this function is activated via software the sensor is looking for the highest object temperature; means the threshold value for activating the LED will be automatically tuned.

This works also if the sensor is aimed at a new object (with probably colder temperature). After expiration of a certain reset time (default setting: 10 s) the sensor will adjust the threshold level for activation of the LED new.

### 5.7.2 Self-diagnostic



---

**At a supply voltage (Vcc)  $\geq$  12 V it takes about 5 minutes until the sensor works in a stable mode. Therefore, after switching on the unit, the LED will show a not stable state for up to 5 minutes.**

---

With this function the current status of the sensor will be indicated by different flash modes of the LED.

If activated, the LED will show one out of five possible states of the sensor:			
Status	LED mode		
Normal	intermittent off	-	- - - -
Sensor overheated	fast flash	-----	
Out of measuring range	double flash	--	-- -- -- -- --
Not stable	intermittent on	---	---
Alarm fault	always on	_____	

### Sensor status

Sensor overheated	The internal temperature probes have detected an invalid high internal temperature of the CS.
Out of meas. range	The object temperature is out of measuring range.
Not stable	The internal temperature probes have detected an unequally internal temperature of the CS.
Alarm fault	Current through the switching transistor of the open-collector output is too high.

### 5.7.3 Temperature code indication

With this function the current measured object temperature will be indicated as percentage value by long and short flashing of the LED. At a range setting of 0-100 °C → 0-100 % the LED flashing indicates the temperature in °C.

Long flashing → first digit:	xx
Short flashing → second digit:	xx
10-times long flashing → first digit=0:	0x
10-times short flashing → second digit=0:	x0

#### Examples

87 °C	8-times long flashing indicates	87
and afterwards	7-times short flashing indicates	87
31 °C	3-times long flashing indicates	31
and afterwards	1-times short flashing indicates	31
8 °C	10-times long flashing indicates	08
and afterwards	8-times short flashing indicates	08
20 °C	2-times long flashing indicates	20
and afterwards	10-times short flashing indicates	20

## 6. Installation

### 6.1 Mechanical Installation

The TIN-SS is equipped with a metric M12x1 thread and can be installed either directly via the sensor thread or with the help of the both hex nuts (standard) to the mounting bracket available.

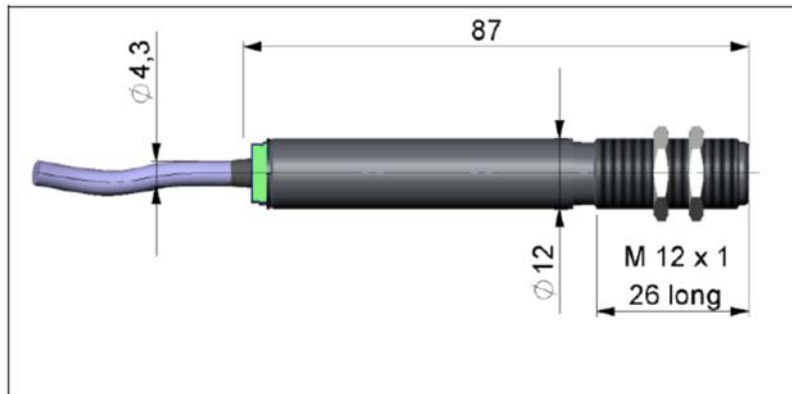

Dimensions TIN-SS

For an exact aiming of the sensor to an object the LED function, see chapter 5.7.1 Automatic aiming support, can be used.

#### 6.1.1 Mounting accessories

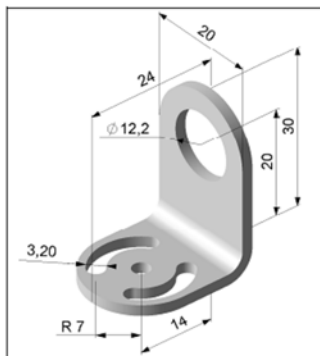

Mounting bracket, adjustable in one axis  
[Order-No.: TIN-ZTFB]

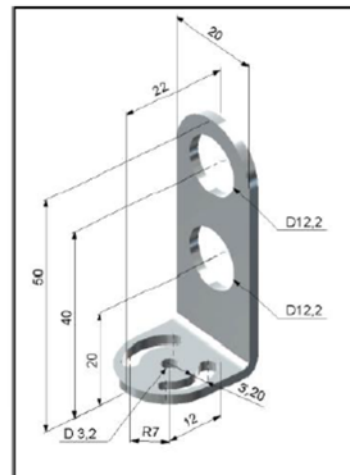

Mounting bracket, adjustable in one axis, probe and laser sighting aid  
[Order No.: TIN-ZTF2]

Laser sighting aid Model TIN-ZTLS

battery  
powered

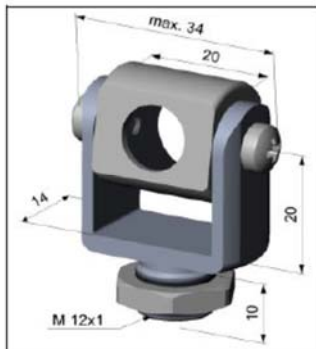

Mounting fork with M12x1 thread,  
Adjustable in two axes  
see air purge collar



Mounting bracket, adjustable in  
two axes  
[Order-No.: TIN-ZTAB]

## 6.1.2 Air purge collar

---



- Use oil-free, technically clean air only.
  - The needed amount of air (approx. 2...10 l/ min.) depends on the application and the installation conditions on-site.
- 

The lens must be kept clean at all times from dust, smoke, fumes and other contaminants in order to avoid reading errors. These effects can be reduced by using an air purge collar.

Free blowing offset, laminar, with mounting fork, adjustable in two axes, model TIN-ZTAP

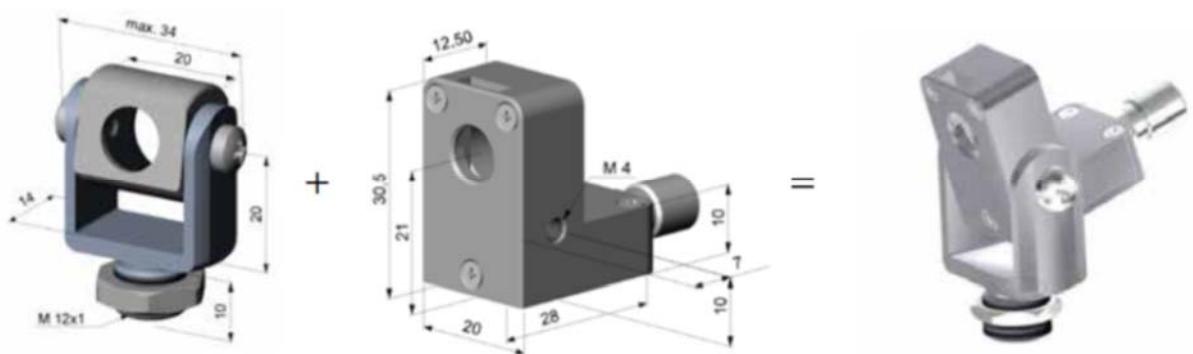

A combination of the laminar air purge collar with the bottom section of the mounting fork allows an adjustment in two axes.  
[Order-No.: TIN-ZTAP]



IR App Connector: USB adapter cable incl. terminal block  
[Order-No.: TIN-ZSIA]



## 7. Electrical Installation



Use a separate, stabilized power supply unit with an output voltage in the range of 5–30 VDC which can supply 100 mA. The residual ripple should be max 200 mV.

**Note: The TIN-SS sensor may only be powered either via USB or externally, but not simultaneously!**



- Use shielded cables only. The sensor shield has to be grounded.
- The shield [black] on the TIN-SS is not connected to GND [brown]. In any case it is necessary to connect the shield to ground or GND (whichever works best)!
- When using the thermocouple and an external power supply, there must be a connection between ground and shield.

Analog device (mV-output at OUT pin)



The output impedance must be  $\geq 10 \text{ k}\Omega$ .

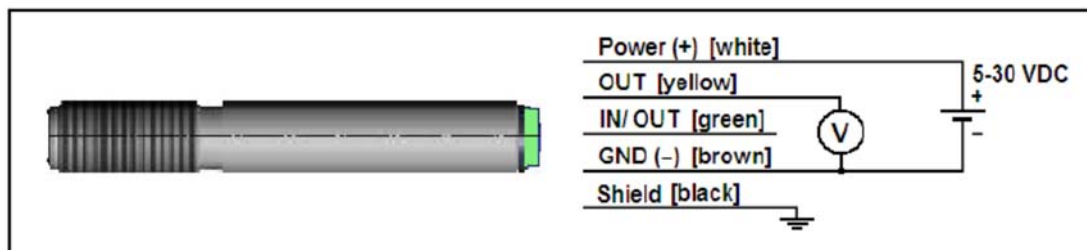

Analog device (mV output at OUT pin)

Analog device (Thermocouple typ K at OUT t/c K pins)



The output impedance must be  $\geq 20 \text{ k}\Omega$ .

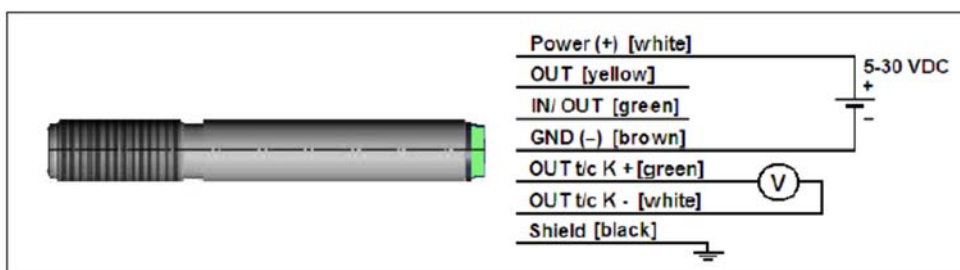

Analog device (Thermocouple typ K at OUT t/c K pins)

You can choose between an mV output (0-5 or 0-10 V; scalable via software) and a thermocouple output type K. Therefore the optional software is needed. The factory default setting is mV output.

The thermocouple output supplies a voltage according to the t/c characteristic curve type K. If you want to extend this output you have to use a suitable thermocouple extension cable (NiCr-Ni).

## 7.1 Digital communication

For a digital communication the optional USB programming kit is required.

1. Connect each wire of the USB adapter cable with the same colored wire of the sensor cable by using the terminal block. Press with a screw driver as shown in the picture to lose a contact.

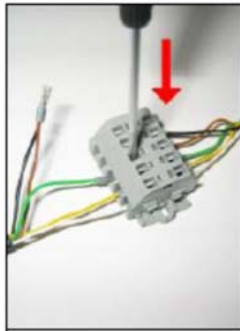

Connection USB cable

The sensor is offering two ways of digital communication:

- bidirectional communication (sending and receiving data)
- unidirectional communication (burst mode – the sensor is sending data only)

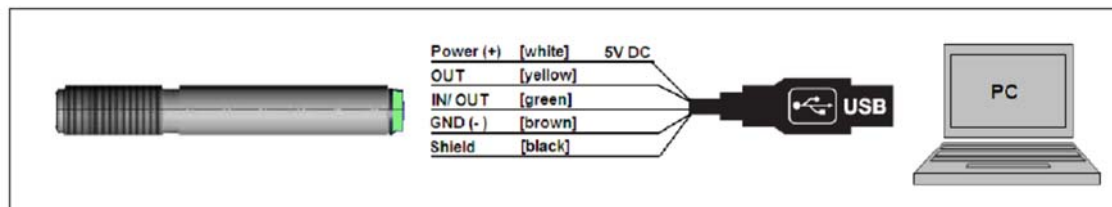

Digital communication

## 7.2 Open collector output



---

**In case of long lines there is a drop voltage at the ground wire and the mV-output is distorted. Because of that the brown wire can be used as ground supply and the t/c- wire (type K) as measuring ground.**

---

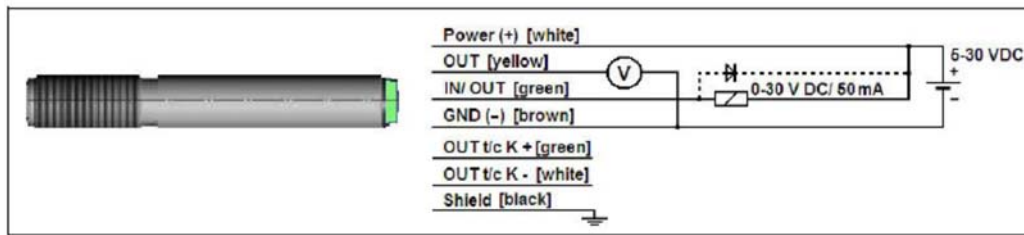

Open collector output as additional alarm output

The open collector output is an additional alarm output on the TIN-SS and can control an external relay e.g. In addition, the analogue output can be used simultaneously.

## 8. Schematic circuit diagrams for maintenance applications

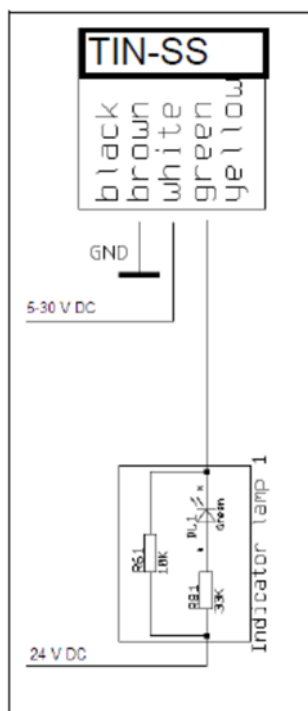

Open collector output for direct 24 V DC signal lamp control

## 9. Software for parameterization

### Minimum system requirements:

- Windows 7, Windows 8, Windows 10
- USB interface
- Hard disc with at least 30 MByte of free space
- At least 128 MByte RAM

The software only supports USB cables ordered directly from Kobold Messring, see USB-interface TIN-ZSIA

### 9.1 Installation

You can download the software for parameterization and data recording for Windows® from the Kobold homepage.

[www.kobold.com/qr/TIN](http://www.kobold.com/qr/TIN)

Please follow the instructions after starting the setup file.

For communication between the sensor and PC, install the drivers for the USB adapter.

If you want to uninstall the software from your system, please use the uninstall function.

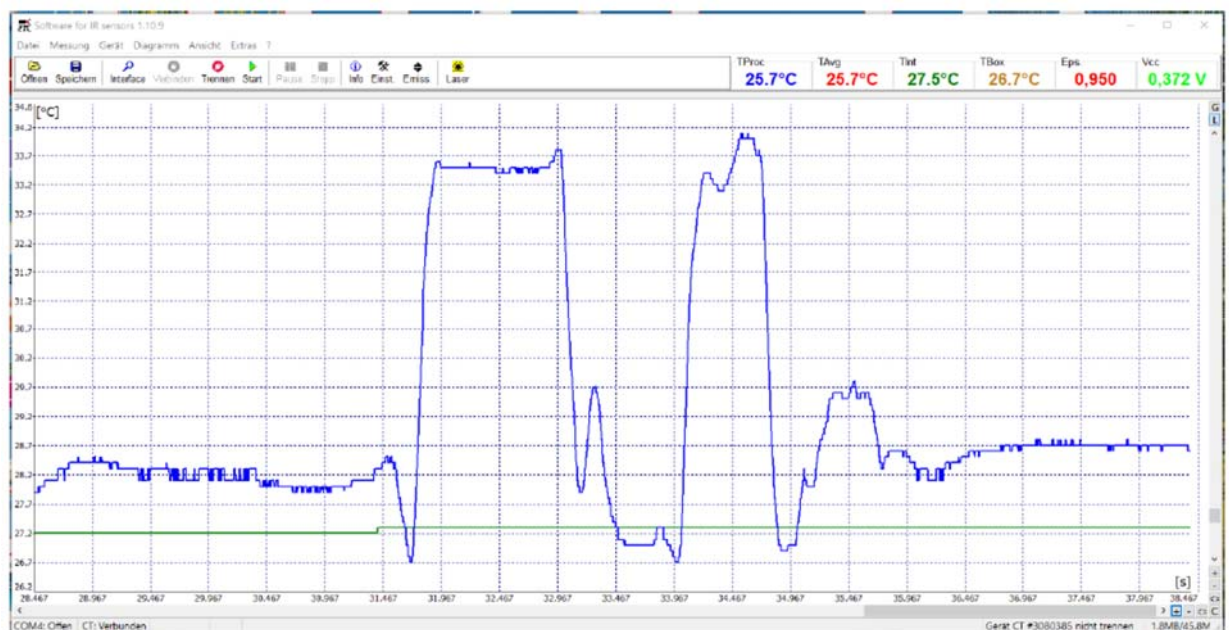

Software for Windows

### Main functions:

- Graphic display for temperature trends and automatic data logging for analysis and documentation
- Complete sensor setup and remote controlling
- Adjustment of signal processing functions
- Programming of outputs and functional inputs

## 9.2 Communication settings

### 9.2.1 Serial Interface

Baud rate:	9,6 / 115,2 kBaud (adjustable via software)
Data bits:	8
Parity:	none
Stop bits:	1
Flow control	off

## 10. Basics of Infrared Thermometry

Depending on the temperature each object emits a certain amount of infrared radiation. A change in the temperature of the object is accompanied by a change in the intensity of the radiation. For the measurement of “thermal radiation” infrared thermometry uses a wave-length ranging between 1  $\mu\text{m}$  and 20  $\mu\text{m}$ . The intensity of the emitted radiation depends on the material. This material contingent constant is described with the help of the emissivity which is a known value for most materials (see chapter 11 Emissivity).

Infrared thermometers are optoelectronic sensors. They calculate the surface temperature on the basis of the emitted infrared radiation from an object. The most important feature of infrared thermometers is that they enable the user to measure objects contactless. Consequently, these products help to measure the temperature of inaccessible or moving objects without difficulties. Infrared thermometers basically consist of the following components:

- lens
- spectral filter
- detector
- electronics (amplifier/linearization/signal processing)

The specifications of the lens decisively determine the optical path of the infrared thermometer, which is characterized by the ratio Distance to Spot size. The spectral filter selects the wavelength range, which is relevant for the temperature measurement. The detector in cooperation with the processing electronics transforms the emitted infrared radiation into electrical signals.

## 11. Emissivity

---

### 11.1 Definition

The intensity of infrared radiation, which is emitted by each body, depends on the temperature as well as on the radiation features of the surface material of the measuring object. The emissivity ( $\epsilon$  – Epsilon) is used as a material constant factor to describe the ability of the body to emit infrared energy. It can range between 0 and 100 %. A “blackbody” is the ideal radiation source with an emissivity of 1.0 whereas a mirror shows an emissivity of 0.1.

If the emissivity chosen is too high, the infrared thermometer may display a temperature value which is much lower than the real temperature – assuming the measuring object is warmer than its surroundings. A low emissivity (reflective surfaces) carries the risk of inaccurate measuring results by interfering infrared radiation emitted by background objects (flames, heating systems, chamottes). To minimize measuring errors in such cases, the handling should be performed very carefully and the unit should be protected against reflecting radiation sources.

### 11.2 Determination of unknown emissivity

- First determine the actual temperature of the measuring object with a thermocouple or contact sensor. Second, measure the temperature with the infrared thermometer and modify the emissivity until the displayed result corresponds to the actual temperature.
- If you monitor temperatures of up to 380°C you may place a special plastic sticker (emissivity dots – on request) onto the measuring object, which covers it completely. Set the emissivity to 0.95 and take the temperature of the sticker. Afterwards, determine the temperature of the adjacent area on the measuring object and adjust the emissivity according to the value of the temperature of the sticker
- Cover a part of the surface of the measuring object with a black, flat paint with an emissivity of 0.98. Adjust the emissivity of your infrared thermometer to 0.98 and take the temperature of the colored surface. Afterwards, determine the temperature of a directly adjacent area and modify the emissivity until the measured value corresponds to the temperature of the colored surface.



---

**CAUTION: On all three methods the object temperature must be different from ambient temperature.**

---

## 11.3 Characteristic emissivity

In case none of the methods mentioned above help to determine the emissivity you may use the emissivity table, see Appendix A and Appendix B. These are average values, only. The actual emissivity of a material depends on the following factors:

- temperature
- measuring angle
- geometry of the surface
- thickness of the material
- constitution of the surface (polished, oxidized, rough, sandblast)
- spectral range of the measurement
- transmissivity (e.g. with thin films)

## 12. Maintenance

---

Blow off loose particles using clean compressed air. The lens surface can be cleaned with a soft, humid tissue (moistened with water) or a lens cleaner (e.g. Purosol or B+W Lens Cleaner).



---

**Never use cleaning compounds which contain solvents (neither for the lens nor for the housing).**

---

## 13. Technical Information

---

Operating instructions, data sheet, approvals and further information via the QR code on the device or via [www.kobold.com](http://www.kobold.com)

## 14. Order Codes

---

Operating instructions, data sheet, approvals and further information via the QR code on the device or via [www.kobold.com](http://www.kobold.com)

## 15. Dimensions

---

Operating instructions, data sheet, approvals and further information via the QR code on the device or via [www.kobold.com](http://www.kobold.com)



## 16. Disposal

### Note!

- Avoid environmental damage caused by media-contaminated parts
- Dispose of the device and packaging in an environmentally friendly manner
- Comply with applicable national and international disposal regulations and environmental regulations.

### Batteries

Batteries containing pollutants are marked with a sign consisting of a crossed-out garbage can and the chemical symbol (Cd, Hg, Li or Pb) of the heavy metal that is decisive for the classification as containing pollutants:

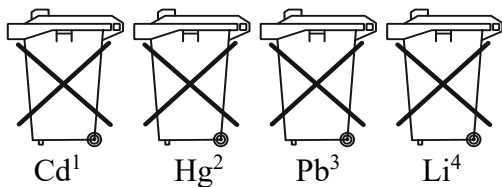

1. „Cd" stands for cadmium
2. „Hg" stands for mercury
3. „Pb" stands for lead
4. „Li" stands for lithium

### Electrical and electronic equipment

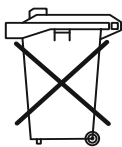

## 17. EU Declaration of Conformance

---

We, KOBOLD Messring GmbH, Nordring 22-24, 65719 Hofheim, Germany, declare under our sole responsibility that the product:

**Infrared Pyrometer Model: TIN-SS**

to which this declaration relates is in conformity with the following EU directives stated below:

<b>2014/30/EU</b>	<b>EMC Directive</b>
<b>2011/65/EU</b>	<b>RoHS (category 9)</b>
<b>2015/863/EU</b>	<b>Delegated Directive (RoHS III)</b>

Also, the following standards are fulfilled:

**EN IEC 61326-1:2021**

Electrical equipment for measurement, control and laboratory use - EMC requirements - Part 1: General requirements

**EN 61326-2-3:2021** Electrical equipment for measurement, control and laboratory use - EMC requirements - Part 2-3: Particular requirements - Test configuration, operational conditions and performance criteria for transducers with integrated or remote signal conditioning

**EN 61010-1:2010 + A1:2019 + A1:2019/AC:2019** Safety requirements for electrical equipment for measurement, control and laboratory use - Part 1: General requirements

**EN 60825-1:2014 + AC:2017 + A11:2021 + A11:2021/AC:2022** Safety of laser products - Part 1: Equipment classification and requirements

**EN IEC 63000:2018** Technical documentation for the assessment of electrical and electronic products with respect to the restriction of hazardous substances

Hofheim, 20 October 2023

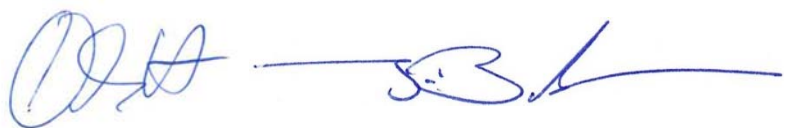

H. Volz  
General Manager

J. Burke  
Compliance Manager

## 18. Appendix A – Table of emissivity for metals

Material		typical Emissivity
Aluminium	non oxidized	0,02-0,1
	polished	0,02-0,1
	roughened	0,1-0,3
	oxidized	0,2-0,4
Brass	polished	0,01-0,05
	roughened	0,3
	oxidized	0,5
Copper	polished	0,03
	roughened	0,05-0,1
	oxidized	0,4-0,8
Chrome		0,02-0,2
Gold		0,01-0,1
Haynes	alloy	0,3-0,8
Inconel	electro polished	0,15
	sandblast	0,3-0,6
	oxidized	0,7-0,95
Iron	non oxidized	0,05-0,2
	rusted	0,5-0,7
	oxidized	0,5-0,9
	forged, blunt	0,9
Iron, casted	non oxidized	0,2
	oxidized	0,6-0,95
Lead	polished	0,05-0,1

Material		typical Emissivity
Lead	roughened	0,4
	oxidized	0,2-0,6
Magnesium		0,02-0,1
Mercury		0,05-0,15
Molybdenum	non oxidized	0,1
	oxidized	0,2-0,6
Monel (Ni-Cu)		0,1-0,14
Nickel	electrolytic	0,05-0,15
	oxidized	0,2-0,5
Platinum	black	0,9
Silver		0,02
Steel	polished plate	0,1
	rustless	0,1-0,8
	heavy plate	0,4-0,6
	cold-rolled	0,7-0,9
	oxidized	0,7-0,9
Tin	non oxidized	0,05
Titanium	polished	0,05-0,2
	oxidized	0,5-0,6
Wolfram	polished	0,03-0,1
Zinc	polished	0,02
	oxidized	0,1

## 19. Appendix B - Table of emissivity for non-metals

Material	typical Emissivity				
	Spectral response	1,0 µm	2,2 µm	5,1 µm	8-14 µm
Asbestos		0,9	0,8	0,9	0,95
Asphalt				0,95	0,95
Basalt				0,7	0,7
Carbon	non oxidized		0,8-0,9	0,8-0,9	0,8-0,9
	graphite		0,8-0,9	0,7-0,9	0,7-0,8
Carborundum			0,95	0,9	0,9
Ceramic		0,4	0,8-0,95	0,8-0,95	0,95
Concrete		0,65	0,9	0,9	0,95
Glass	plate		0,2	0,98	0,85
	melt		0,4-0,9	0,9	
Grit				0,95	0,95
Gypsum				0,4-0,97	0,8-0,95
Ice					0,98
Limestone				0,4-0,98	0,98
Paint	non alkaline				0,9-0,95
Paper	any color			0,95	0,95
Plastic >50 µm	non transparent			0,95	0,95
Rubber				0,9	0,95
Sand				0,9	0,9
Snow					0,9
Soil					0,9-0,98
Textiles				0,95	0,95
Water					0,93
Wood	natural			0,9-0,95	0,9-0,95

## 20. Appendix D – Smart Averaging

---

The average function is generally used to smoothen the output signal. With the adjustable parameter time this function can be optimal adjusted to the respective application. One disadvantage of the average function is that fast temperature peaks which are caused by dynamic events are subjected to the same averaging time. Therefore, those peaks can only be seen with a delay on the signal output.

The function Smart Averaging eliminates this disadvantage by passing those fast events without averaging directly through to the signal output.

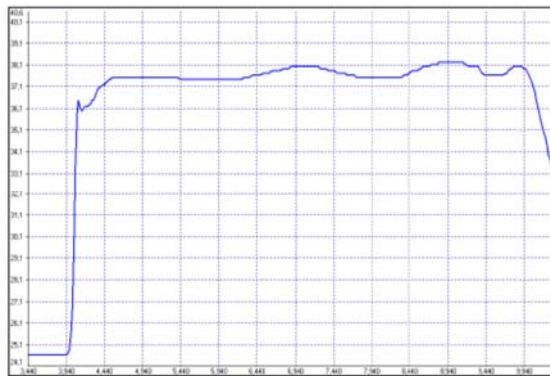

Signal graph with Smart Averaging function



Signal graph without Smart Averaging function